

Code G21.1

Ersatzteilliste
Spare parts catalogue
Catalogue des pièces

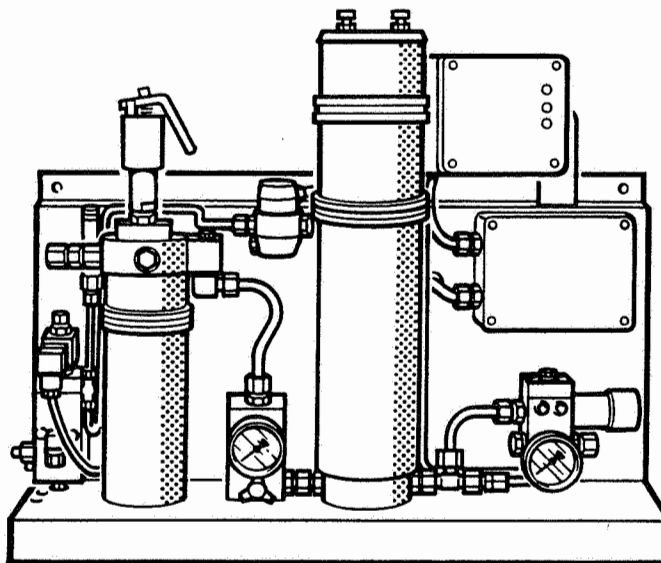

Filtersystem
Filter system
Système de filtration

P40 II 420 bar (6000 psi)
P40 IIJ 350 bar (5000 psi)

Baugruppe

Assembly

Groupe d'assemblage

Seite/Page

Öl und Wasserabscheider	Oil and water separator	Séparateur d'huile et d'eau	G21.1-1
Feinnachreiniger mit SECURUS	Final purifier with SECURUS	Epurateur avec SECURUS	G21.1-2
Druckhalte- u. Rückschlagventil 056705-341	Pressure maintaining and non-return 056705-341	Clapet de maintien de pression anti-retour 056705-341	G21.1-3
Druckhalte- u. Rückschlagventil 063838-341	Pressure maintaining and non-return 063838-341	Clapet de maintien de pression anti-retour 063838-341	G21.1-4
Kondensatablaßautomatik	Automatic condensate drain	Purge automatique des condensats	G21.1-5
Kondensatablaßventil	Condensate drain valve	Bloc de purge des condensats	G21.1-6
Elektrische Laufschtwerke	Electrical timers	Minuteriers électriques	G21.1-7

Änderungsblatt:
Change record :
Table des changements:

G21

Änder. Nr. Change No. No. de changem.	Datum Date	Änderung	Change	Changement
0	28.04.88	Grundaussgabe	Basic edition	Edition de base
1	06.08.90	Kondensatablaßautomatik, neuer Öl- und Wasserabscheider	Automatic condensate drain, new oil and water separator	Purge automatique des condensats, nouveau séparateur d'huile et d'eau

Wichtige Hinweise für Teilebestellung:

Bestell-Nr., die mit der Ziffer 0 beginnen, bezeichnen Teile, die komplett geliefert werden.

Teile ohne Bestell-Nr. sind nur zur Information für die Montage aufgeführt. Diese Teile sind nicht als Ersatzteile erhältlich.

Bei Ersatzteilbestellungen erwarten Sie unsere richtige Lieferung; deshalb benötigen wir von Ihnen folgende Angaben:

1. Filtertyp
2. Fabrik-Nr.
3. Stückzahlen
4. Benennung und Bestell-Nr. des gewünschten Teils.

Bestell-Beispiel:

Für Filtersystem P40 II
3 Dichtungen Nr. N 4466



Ersatzteilsätze

Klassifizierung:

0 = Dichtungssatz Bestell-Nr. N 6224
2 = Wartungssatz, 2 Jahre, Bestell-Nr. N 6225
5 = Wartungssatz, 5 Jahre, Bestell-Nr. N 6226

In den Spalten ist jeweils die im entsprechenden Satz enthaltene Teile-Stückzahl angegeben

ACHTUNG:

Nur Schrauben und Stiftschrauben der Qualität 8.8 verwenden!

Important notes for spare parts orders:

Part Nos. beginning with digit 0 indicate parts available as complete assemblies.

Parts without Part No. are indicated for assembly reference only. These parts are not available as single parts.

When placing an order for spare parts, please give the following items so as to ensure our correct delivery:

1. Filter system
2. Serial No.
3. Quantity req'd
4. Name and Part No.

Example for order:

For Filter system P40 II
3 gaskets part no. N 4466



Spare Parts Sets

Classification:

0 = Set of gaskets PartNo. N 6224
2 = Maintenance kit, 2 years; PartNo. N 6225
5 = Maintenance kit, 5 years; PartNo. N 6226

The columns contain the number of parts that are included in the respective parts set

ATTENTION:

Use only screws and studs in quality 8.8. This quality is equivalent to SAE J 429 d grade 5.

Avis important pour la commande de pièces:

Les nos. de commande commençant par le chiffre 0 indiquent les pièces livrées au complet.

Les pièces sans no. de commande sont indiquées uniquement pour information de montage. Elles ne sont pas livrables individuellement.

Pour que notre livraison de pièces de rechange corresponde à votre commande, veuillez bien nous fournir les données suivantes:

1. Système du filtration
2. No. de fabrication du système
3. Quantité désirée
4. Désignation et no. de cde. de la pièce désirée.

Exemple de commande:

Pour système de filtrage P40 II
3 joints No. de cde. N 4466



Kits de pièces détachées

Classification:

0 = Kit de joints d'étanchéité, No. de cde. N 6224
2 = Kit d'entretien pour 2 ans, No. de cde. N 6225
5 = Kit d'entretien pour 5 ans, No. de cde. N 6226

Le nombre des pièces contenues dans les kits est indiquée dans les colonnes.

ATTENTION:

N'utiliser que des vis et des goujons filetés de la qualité 8.8

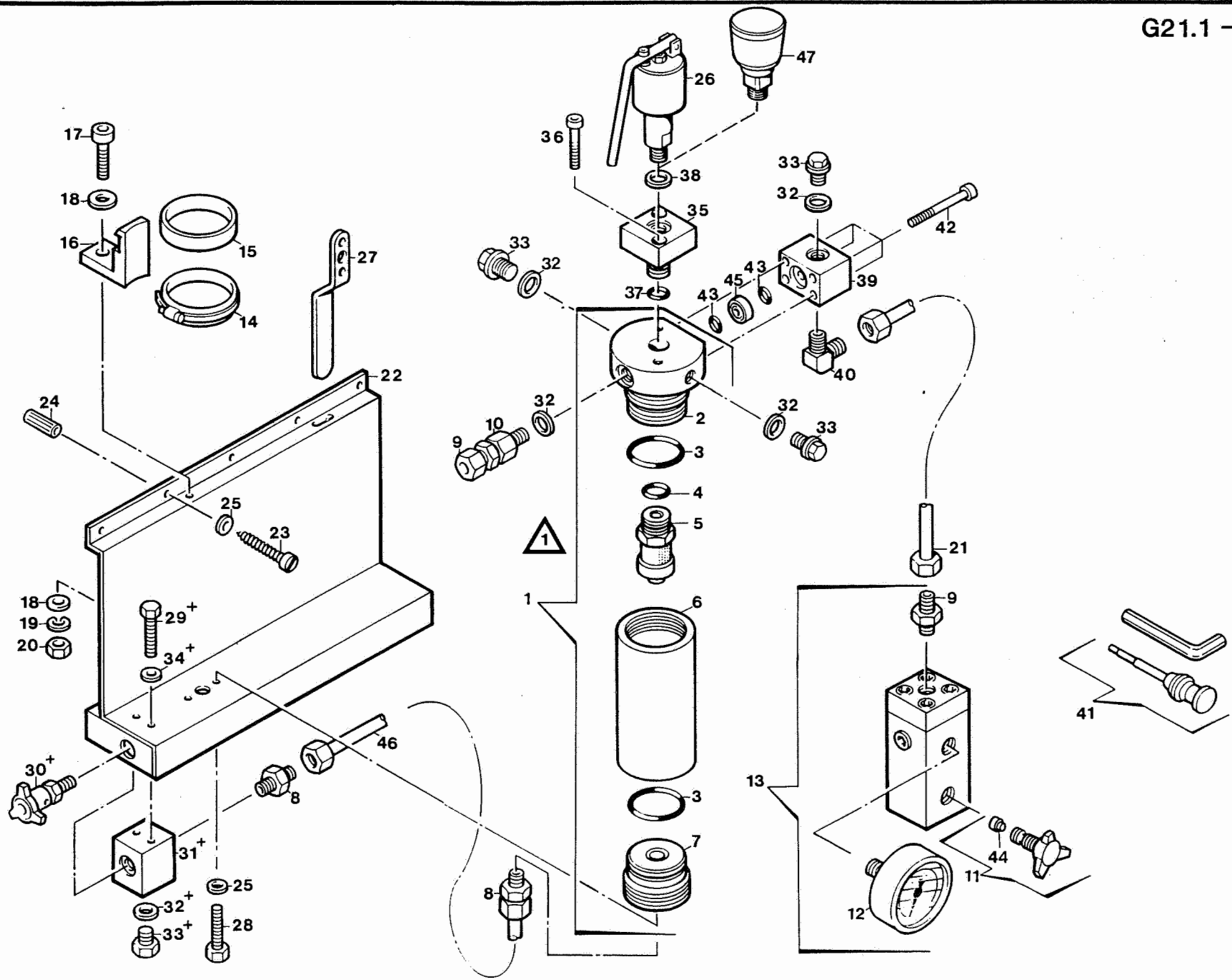

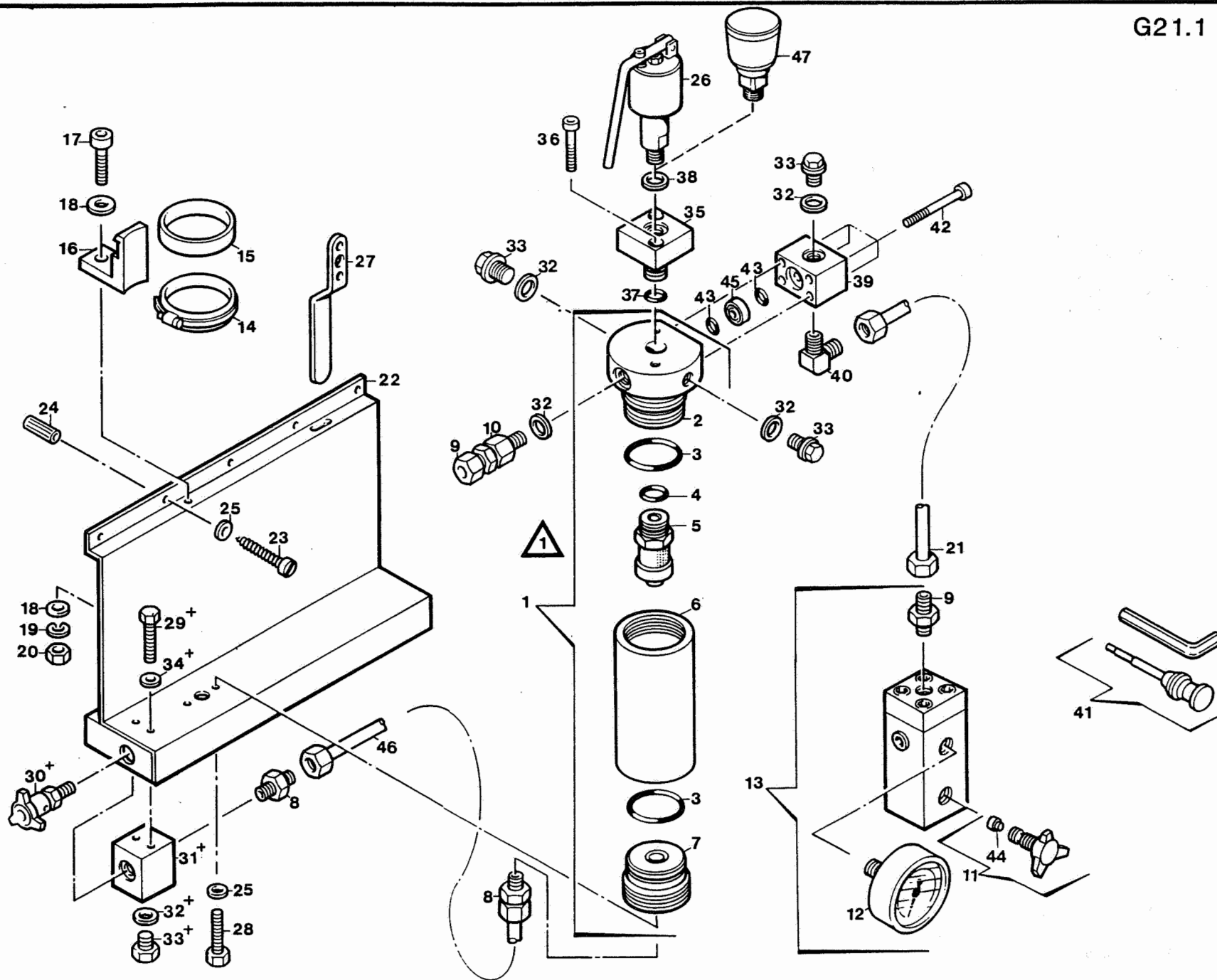



Ersatzteilsätze
Spare parts sets
Kits de pièces dét.

Bildtafel G21.1-1 Öl- und Wasserabscheider
Figure G21.1-1 Oil and Water Separator
Planche G21.1-1 Séparateur d'huile et d'eau

Änderung Nr.
Change No.
No. de changem.



Klasse Class Classe			Pos.	Bestell-Nr. Part No. No. de cde.	Benennung	Designation	Dénomination	Gewicht Weight Poids (kg)	Abmessungen Dimensions Dimensions
0	2	5							
1	1	2	36	N 61	Innensechskantschraube	Allen screw	Vis à six pans creux	0.015	M 8 x 25 DIN 912
			37	N 4882	O-Ring	O-ring	Joint torique	0.001	Ø 16 x 2
1	1	2	38	N 4499	Dichtring	Gasket	Joint	0.002	U 16,7 x 24 x 1,5
			39	90059-430	Zwischenstück	Intermediate piece	Pièce intermédiaire		3/8"
			40	N 17354	Winkelrohrverschraubung	Male elbow	Raccord coudé mâle	0.134	WE 10 PSR-ED
	1	1	41	067458-645	Werkzeugsatz f. Knebelschraube	Tool set for tommy screw	Jeu d'outils pour robinet		
2	2	4	42	N 724	Innensechskantschraube	Allen screw	Vis à six pans creux	0.011	M 6 x 40 DIN 912
			43	N 4178	O-Ring	O-ring	Joint torique	0.001	Ø 17 x 2,6
1	1	2	44	64498-635	Dichtung	Gasket	Joint		
			45	63998-430	Verbindungsniessel	Connecting part	Pièce intermédiaire		
			46	N 3616**	Verbindungsleitung	Connecting tube	Conduite de connexion		Ø 6 x 1 DIN 2464
			47	011523-340	Sicherheitsventil	Safety valve	Soupape de sûreté		P 40 II J 330 bar
				*	Nur zusammen erhältlich	Only available together	Ne sont livrés qu'ensemble		
				**	Meterware; bei Bestellung Länge angeben	Piece goods; specify length on order	Marchandise au mètre; indiquer longueur à la commande		
				+	Entfällt bei Kondensatablaß-automatik	Not used with automatic condens. drain	Pièces ne pas montés avec purge automatique		

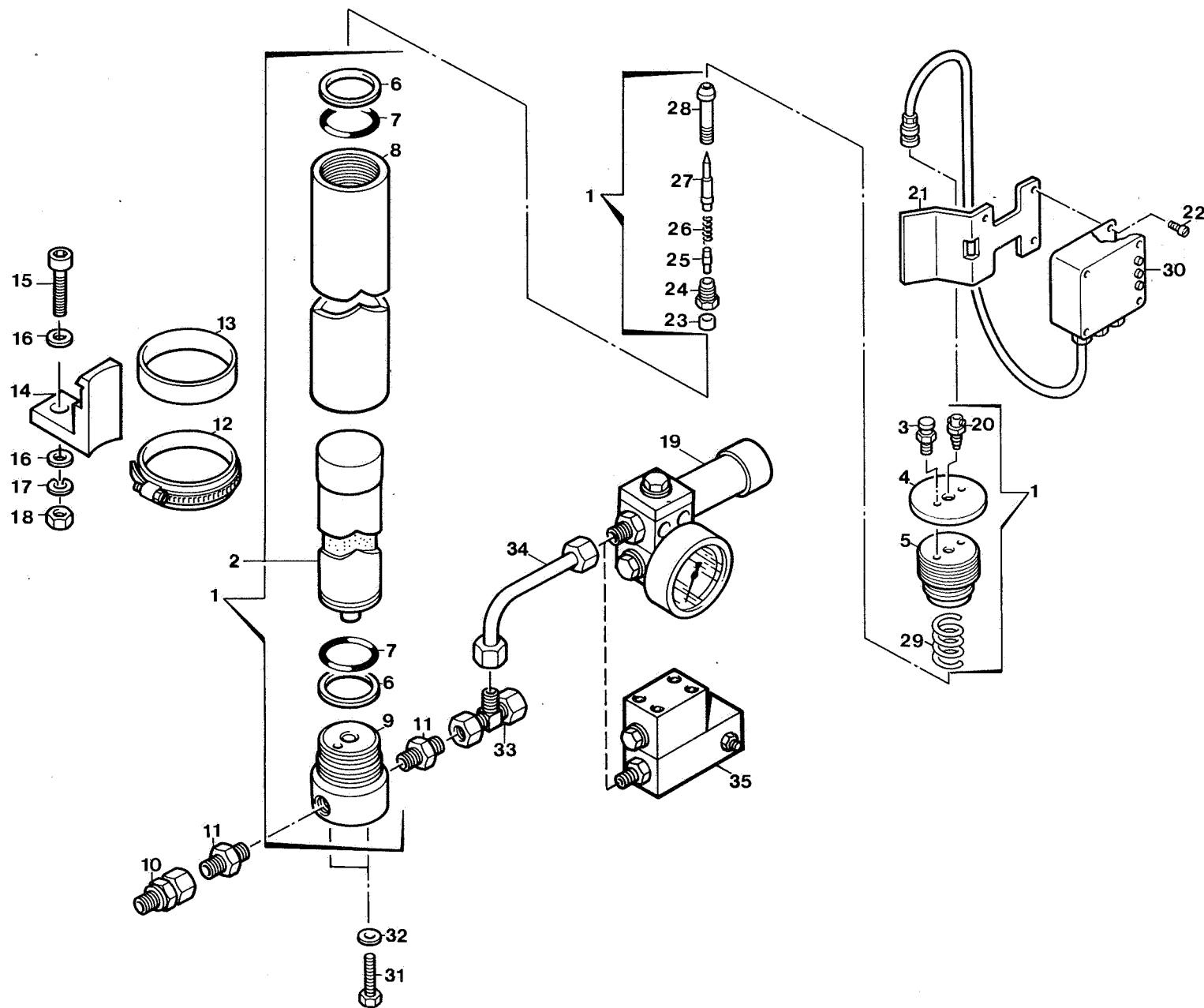



Ersatzteilsätze
Spare parts sets
Kits de pièces dét.

Bildtafel G21.1-2 Feinnachreiniger mit SECURUS
Figure G21.1-2 Final purifier with SECURUS
Planche G21.1-2 Epurateur avec SECURUS

Klasse Class Classe			Pos.	Bestell-Nr. Part No. No. de cde.	Benennung	Designation	Dénomination	Gewicht Weight Poids (kg)	Abmessungen Dimensions Dimensions	
0	2	5								
			1	065484-410	HD-Filter kpl., o. Patrone	HP-purifier assy., without cartr.	Epurateur-HP cpl.,sans cartouche		P40 II	
			2	068722-410	HD-Filter kpl., o. Patrone	HP-purifier assy., without cartr.	Epurateur-HP cpl.,sans cartouche		P40 II J	
			2	061686-410*	Filterpatrone MS-AC-MS	Filter cartridge MS-AC-MS	Cartouche filtrante MS-AC-MS			
				061687-410*	Filterpatrone MS-AC-MS-HP	Filter cartridge MS-AC-MS-HP	Cartouche filtr. MS-AC-MS-HP			
			3	12293-410	Befestigungsschraube	Fastening screw	Vis de fixation			
			4	65490-410	Schutzdeckel	Cover	Protection			
			5	065491-410**	Verschraubung, oben	Plug, top	Chapeau de filtre			
2	2	4	6	N 4736	Stützring	Back up ring	Bague de retenue		Ø 63.69	
2	2	4	7	N 4735	O-Ring	O-ring	Joint torique		Ø 62.87 x 5.33	
			8	65313-410**	Filtergehäuse	Filter housing	Corps de filtre			
			9	61078-410**	Filterboden	Filter base	Fond de filtre			
			10	N 15501	Gerade Rohrverschraubung	Male connector	Raccord droit mâle	0.082	EVGE 10-PSR-ed	
			11	N 4024	Gerade Rohrverschraubung	Male connector	Raccord droit mâle	0.088	GE 10-PSR-ed	
			12	N 17054	Schneckenengewindeschelle	Clamp	Collier pour tuyaux			
			13	N 15500	Gummiprofil	Rubber	Profilé en caoutchouc			
			14	61646-410	Befestigungswinkel	Bracket	Fixation			
			15	N 2505	Innensechskantschraube	Allen screw	Vis à six pans creux	0.0014	M 8 x 30	DIN 6912
			16	N 58	Scheibe	Washer	Rondelle	0.009	Ø 8,4	DIN 7349
			17	N 108	Federring	Lock Washer	Rondelle élastique	0.002	A 8	DIN 127
			18	N 57	Sechskantmutter	Hex. nut	Ecrou hexagonal	0.005	M 8	DIN 934
			19	056705-341	Druckhalte- und Rückschlag-ventil kpl.	Press. maintaining and non-return valve assy.	Clapet de maintien de pression/anti-retour		P 40 II	420 bar
			20	59850-410	HF-Einbaubuchse	RF socket	Connecteur H.F.			
			21	65759-410	Halterung	Bracket	Fixation			
			22	N 2813	Schraube	Screw	Vis	0.002	M 4 x 12	DIN 84
			23	59855-410	Mutter	Nut	Ecrou			
			24	59852-410	Spannschraube	Drawback screw	Vis de tension	0.057		
			25	59854-410	Stift	Stud	Goujon fileté	0.001		
			26	60062-640	Druckfeder	Spring	Ressort de pression			
			27	59853-410	Stift	Stud	Goujon fileté	0.001		
			28	59851-410	Stopfen	Plug	Bouchon fileté	0.005		
			29	2181-640	Feder	Spring	Ressort			
			30	N 15094***	SECURUS Meldegerät	SECURUS Indicator unit	Dispositif SECURUS		190-250 V	
				N 15095***	SECURUS Meldegerät	SECURUS Indicator unit	Dispositif SECURUS		110-127 V	
			31	N 570	Sechskantschraube	Hex. bolt	Vis hexagonale	0.021	M 10 x 16	DIN 933
			32	N 16	Scheibe	Washer	Rondelle	0.004	Ø 10,5	DIN 125
			33	N 4599	Einstellb. L-Rohrverschraubung	Adjustable male run Tee	Raccord coudé en T orient.	0.216	EVL 10-PSR	
			34	N 4699****	Verbindungsleitung	Connecting tube	Conduite de connexion		Ø 10x1,5x	
			35	063838-341	Druckhalte und Rückschlag-ventil kpl.	Pressure maintaining and non-return valve assy.	Clapet de maintien de pression/anti-retour		P 40 II J	DIN 2464 330 bar
				*	Wahlweise	Optional	Optionnel			
				**	Nur zusammen erhältlich	Only available together	Ne sont livrés qu'ensemble			
				***	Bei Bestellung Spannung und Frequenz angeben.	Please specify voltage and frequency on order.	Veillez indiquer voltage et fréquence à la commande			
				****	Meterware; bei Bestellung Länge angeben	Piece goods; specify length on order	Marchandise au mètre; indiquer longueur à la commande			

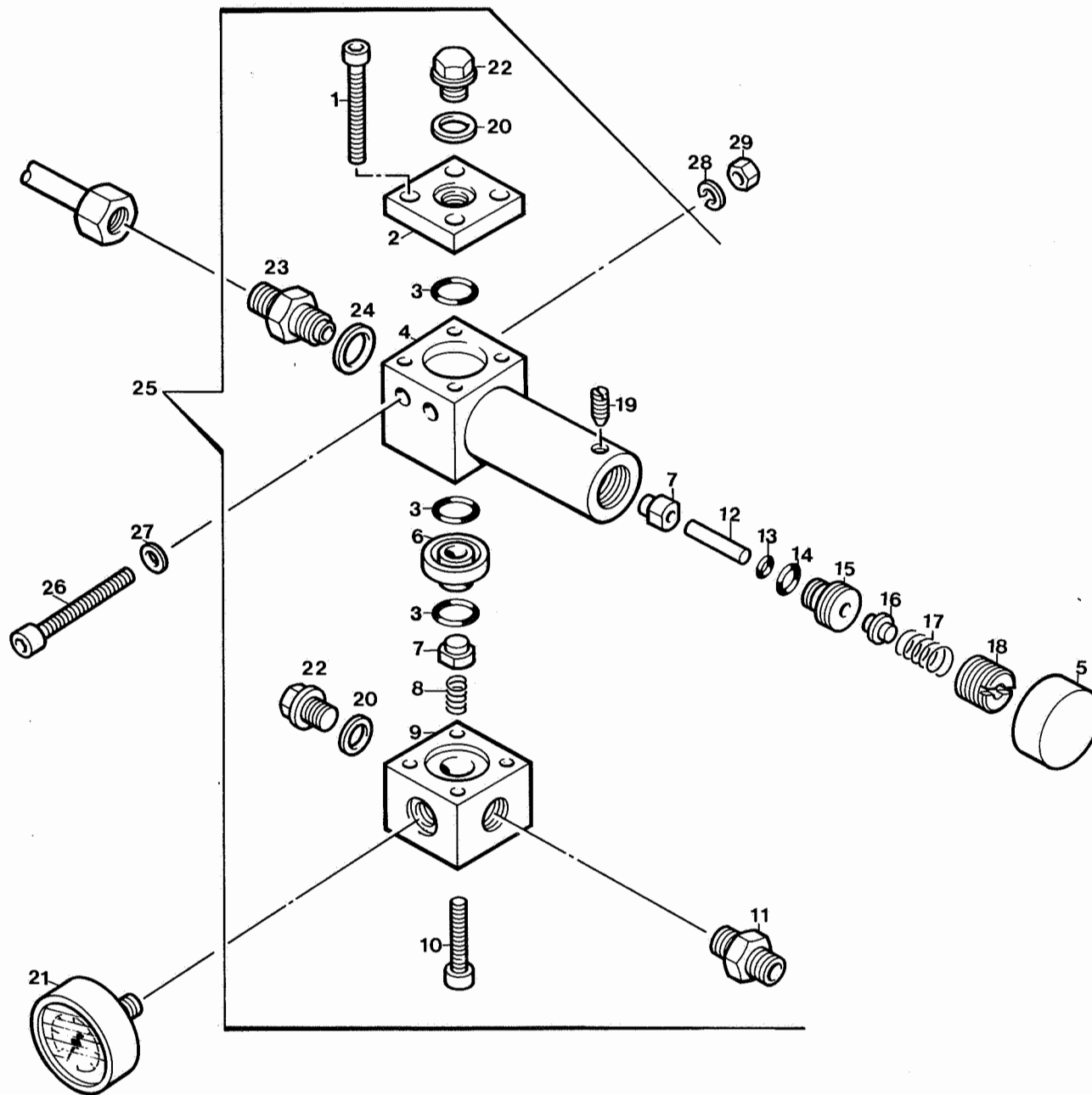



Ersatzteilsätze
Spare parts sets
Kits de pièces dét.

Bildtafel G21.1-3 Druckhalte- und Rückschlagventil 056705-341
Figure G21.1-3 Pressure maintaining and non-return valve 056705-341
Planche G21.1-3 Soupape de maintien de pression/anti-retour 056705-341

Klasse Class Classe			Pos.	Bestell-Nr. Part No. No. de cde.	Benennung	Designation	Dénomination	Gewicht Weight Poids (kg)	Abmessungen Dimensions Dimensions			
0	2	5										
3	3	6	1	N 210	Innensechskantschraube	Allen screw	Vis à six pans creux	0.007	M 6 x 20 DIN 912			
			2	56736-341	Blindflansch	Cover plate	Couvercle	0.100				
			3	N 4178	O-Ring	O-ring	Joint torique	0.001	Ø 17,12 x 2,62			
			4	56671-341	Ventilkörper	Valve body	Corps de clapet	0.425				
			5	N 16773	Staubkappe	Dust cap	Chapeau		Ø 38			
			1	2	6	63843-341	Rückschlagventilsitz	Non-return valve seat	Siège de clapet anti-retour	0.050		
			2	4	7	056674-341	Ventilkolben	Valve piston	Piston de clapet	0.004		
			1	2	8	3089-640	Druckfeder	Spring	Ressort de pression	0.001		
					9	56672-341	Ventilkörper	Valve body	Corps de clapet	0.200		
					10	N 3883	Innensechskantschraube	Allen screw	Vis à six pans creux	0.012	M 6 x 45 DIN 912	
					11	N 4024	Gerade Rohrverschraubung	Male connector	Raccord droit mâle	0.088	GE 10-PSR-ed	
			1	1	1	12	56739-341	Bolzen	Pin	Boulon	0.006	
					2	13	N 16591	O-Ring	O-ring	Joint torique	0.001	Ø 5 x 1,5
						14	N 16631	O-Ring	O-ring	Joint torique	0.001	Ø 12 x 1,5
						15	56677-341	Verschraubung	Plug	Bouchon fileté	0.003	
						16	56675-341	Federaufnahme	Spring guide	Siège de ressort	0.010	
				1	2	17	2623-640	Druckfeder	Spring	Ressort de pression	0.015	
						18	57517-341	Einstellschraube	Setting screw	Vis de réglage	0.035	
						19	N 4465	Gewindestift	Stud	Vis sans tête	0.001	M 4 x 10 DIN 553
			2	2	2	20	N 4602	USIT-Ring	USIT-ring	Joint USIT	0.001	U 14x18,7x1,5
						21	N 17062	Manometer	Pressure gauge	Manomètre		420 bar
						22	N 52	Verschlußschraube	Plug	Bouchon fileté	0.020	R 1/4" DIN 910
						23	56673-341	Druckhalteventilsitz	Pressure maintaining valve seat	Siège de clapet de maintien de pression	0.070	
1	1	1	24	N 4499	USIT-Ring	USIT-ring	Joint USIT	0.001	U 16,7x24x1,5			
			25	056705-341	Druckhalte- und Rückschlagventil kpl.	Pressure maintaining and non-return valve assy.	Clapet de maintien de pression et anti-retour cpl.	1.100	Ø 10, max. 400 bar			
			26	N 1235	Innensechskantschraube	Allen screw	Vis à six pans creux	0.031	M 8 x 65 DIN 912			
			27	N 58	Scheibe	Washer	Rondelle	0.002	B 8,4 DIN 125			
			28	N 108	Federring	Spring ring	Rondelle élastique	0.002	A 8 DIN 127			
			29	N 57	Sechskantmutter	Hex. nut	Ecrou hex.	0.005	M 8 DIN 934			

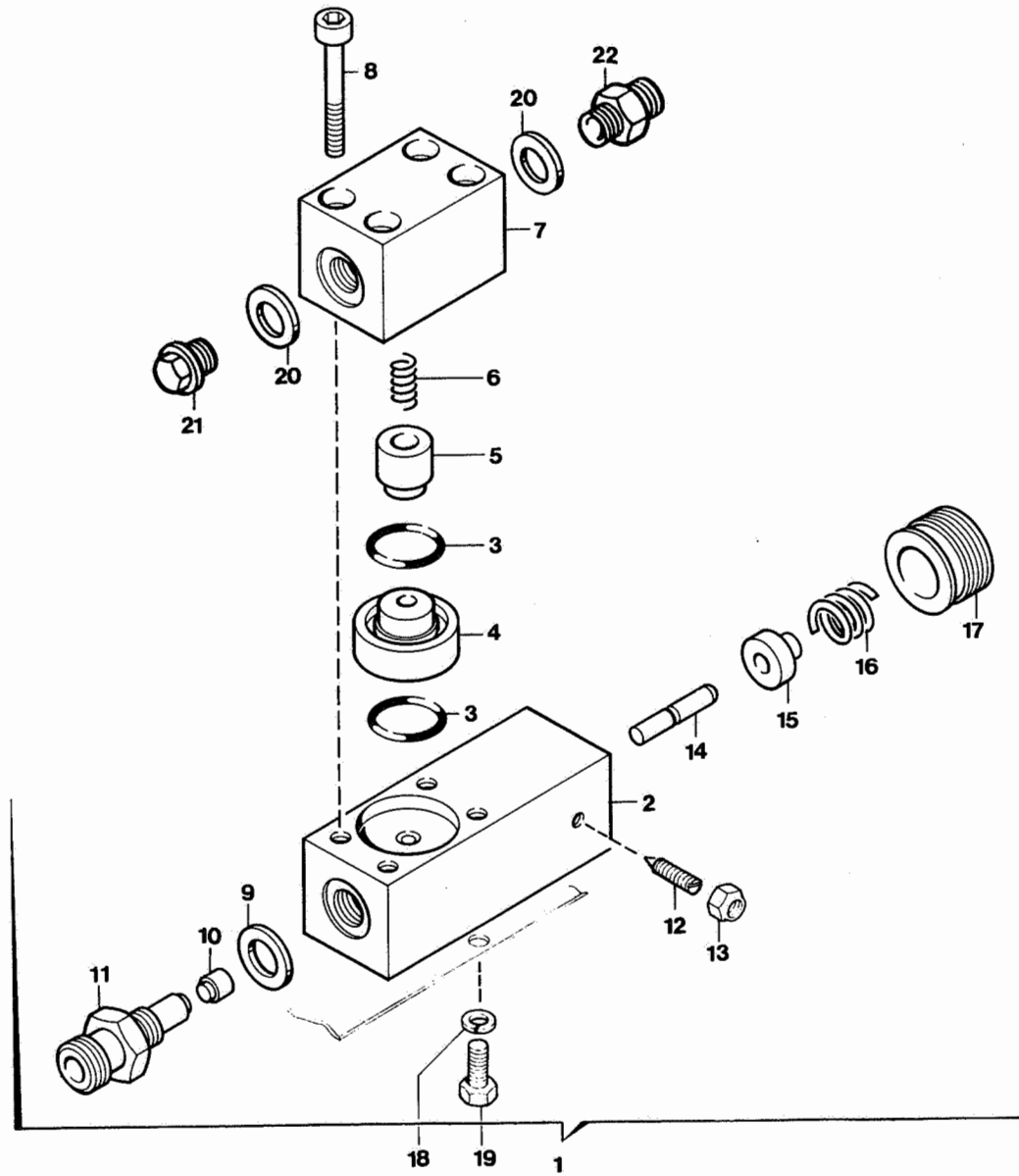



Ersatzteilsätze
Spare parts sets
Kits de pièces dét.

Bildtafel G21.1-4 Druckhalte- und Rückschlagventil 063838-341
Figure G21.1-4 Pressure maintaining and non-return valve 063838-341
Planche G21.1-4 Soupape de maintien de pression/anti-retour 063838-341

Klasse Class Classe			Pos.	Bestell-Nr. Part No. No. de cde.	Benennung	Designation	Dénomination	Gewicht Weight Poids (kg)	Abmessungen Dimensions Dimensions
0	2	5							
			1	063838-341	Druckhalte- u. Rückschlagventil, kpl.	Pressure maintaining and non-return valve, assy	Clapet de maintien de press. anti-retour cpl.		
			2	63839-341	Ventilkörper	Valve body	Corps de clapet		
			3	N 4178	O-Ring	O-ring	Joint torique		Ø 17,12 x 2,62
			4	63843-341	Rückschlagventilsitz	Seat of non-return valve	Siège de clapet anti-retour		
			5	056674-341	Ventilkolben kpl.	Valve piston assy.	Piston de clapet		
			6	3089-640	Druckfeder	Pressure spring	Ressort de pression		
			7	63840-341	Ventilkörper	Valve body	Corps de clapet		
			8	N 724	Innensechskantschraube	Allen screw	Vis à six pans creux	0.011	M 6 x 40 DIN 912
			9	N 4602	USIT-Ring	USIT-ring	Joint USIT		Ø 18,7 x 1,5
			10	57735-341	Ventilkolben	Valve piston	Piston de clapet		
			11	63841-341	Druckhalteventilsitz	Pressure maintaining valve seat	Siège de la clapet de maintien de pression		
			12	N 4465	Gewindestift	Stud	Vis sans tête	0.001	M 4 x 10 DIN 553
			13	N 3837	Sechskantmutter	Hex. nut	Ecrou hex.	0.001	NM 4 DIN 980
			14	066112-341	Druckstift	Pressure pin	Cheville de pression		
			15	57762-341	Federaufnahme	Spring seat	Siège de ressort		
			16	2623-640	Druckfeder	Spring	Ressort de pression		
			17	57935-341	Einstellschraube	Adjusting screw	Vis de réglage		
			18	N 100	Federring	Lock washer	Rondelle élastique	0.001	A 6 DIN 127
			19	N 101	Sechskantschraube	Hex. bolt	Vis hexagonale	0.006	M 6 x 20 DIN 933
			20	56983-090	Dichtung	Gasket	Joint		
			21	N 4570	Verschlussschraube	Plug	Bouchon fileté	0.015	R 1/4" DIN 908
			22	N 3811	Gerade Rohrverschraubung	Male connector	Raccord droit mâle	0.055	GE 8-PSR R 1/4"

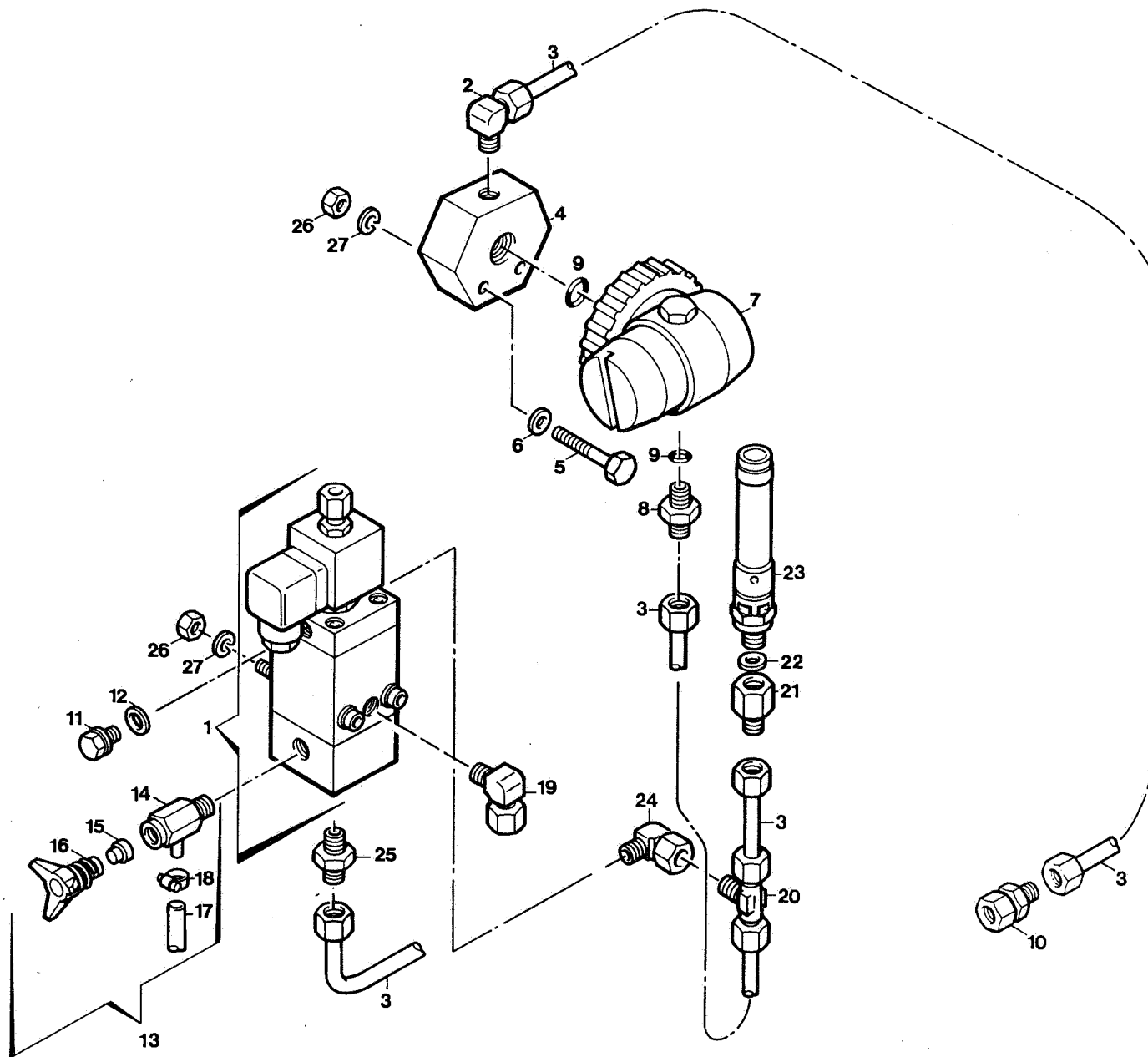



Ersatzteilsätze
Spare parts sets
Kits de pièces dét.

Bildtafel G21.1-5 Kondensat-Ablaufautomatik *
Figure G21.1-5 Automatic condensate drain *
Planche G21.1-5 Purge automatique des condensats *

Änderung Nr.
Change No.
No. de changem.



Klasse Class Classe			Pos.	Bestell-Nr. Part No. No. de cde.	Benennung	Designation	Dénomination	Gewicht Weight Poids (kg)	Abmessungen Dimensions Dimensions
0	2	5							
			1	060412-342	Kondensatablaufventil kpl.	Condensate drain valve assy.	Bloc de purge des cond. cpl.	1.230	
			2	N 1048	Winkelrohrverschraubung	Male elbow	Raccord coudé mâle	0.072	WE 6 PSR
			3	N 3616**	Verbindungsleitung	Connecting tube	Conduite de connexion		Ø 6 x 1 DIN 2462
			4	56931-635	Aufnahme für Druckminderer	Adapter for pressure reducer	Support pour détenteur		R 5/8"
			5	N 1553	Sechskantschraube	Hex. bolt	Vis hexagonale	0.004	M 6 x 12 DIN 933
			6	N 102	Scheibe	Washer	Rondelle	0.001	Ø 6,4 DIN 125
			7	N 4753	Druckminderer	Pressure reducer	Détendeur		10 bar, 5/8"
			8	58597-635	Gerade Rohrverschraubung	Male connector	Raccord droit mâle		
2	2	4	9	N 3355	O-Ring	O-ring	Joint torique	0.001	Ø 7,65 x 1,78
			10	N 4252	Reduzieranschluß	Thread reducer	Raccord réducteur	0.070	KOR 10/6 PS
			11	N 15688	Verschlußschraube	Plug	Bouchon fileté		
1	2	2	12	N 4051	Dichtung	Gasket	Joint	0.001	A 10 x 15 DIN 7603
	1	2	13	011430-635	Kondensatablaufhahn	Drain valve assy	Robinet de purge de condensat	0.075	
			14	068410-635	Ablaufhahnkörper	Drain valve body	Corps de robinet de purge	0.055	
2	2	4	15	13283-090	Dichtung	Gasket	Joint	0.001	
			16	055888-635	Knebelschraube m. Sich.-Feder	Tommy screw with spring	Robinet avec ressort	0.020	
			17	N 1055	Plastikschlauch	Plastic hose	Tuyau en plastique		LW 5 x 1
			18	N 1054	Schlauchklemme	Hose clamp	Collier pour tuyaux		Ø 7 - Ø 9
			19	N 1665	Winkelrohrverschraubung	Male elbow	Raccord coudé mâle	0.083	WE 10 PRL
			20	N 4157	Einstellb. T-Verschraubung	Adjustable male branch Tee	Raccord en T orientable	0.068	EVT 6 PRL
			21	N 3569	Gerade Rohrverschraubung	Male connector	Raccord droit mâle	0.105	MAV 6 PSR 1/4"
1	1	2	22	N 4602	USIT-Ring	USIT ring	Joint USIT	0.001	U 14x18,7x1,5
			23	N 17938	Sicherheitsventil	Safety valve	Soupape de sûreté		14 bar
			24	N 1057	Winkelrohrverschraubung	Male elbow	Raccord coudé mâle	0.040	WE 6 PRL
			25	N 3816	Gerade Rohrverschraubung	Male connector	Raccord droit mâle	0.050	GE 6 PSR-ed
			26	N 287	Sechskantmutter	Hex. nut	Ecrou hexagonal	0.003	M 6 DIN 934
			27	N 100	Federring	Lock washer	Rondelle élastique	0.004	
				*	Zusatzausstattung	Optional extra	Accessoire optionnel		
				**	Meterware; bei Bestellung Länge angeben	Piece goods; specify length on order	Marchandise au mètre; indiquer la longueur à la commande		

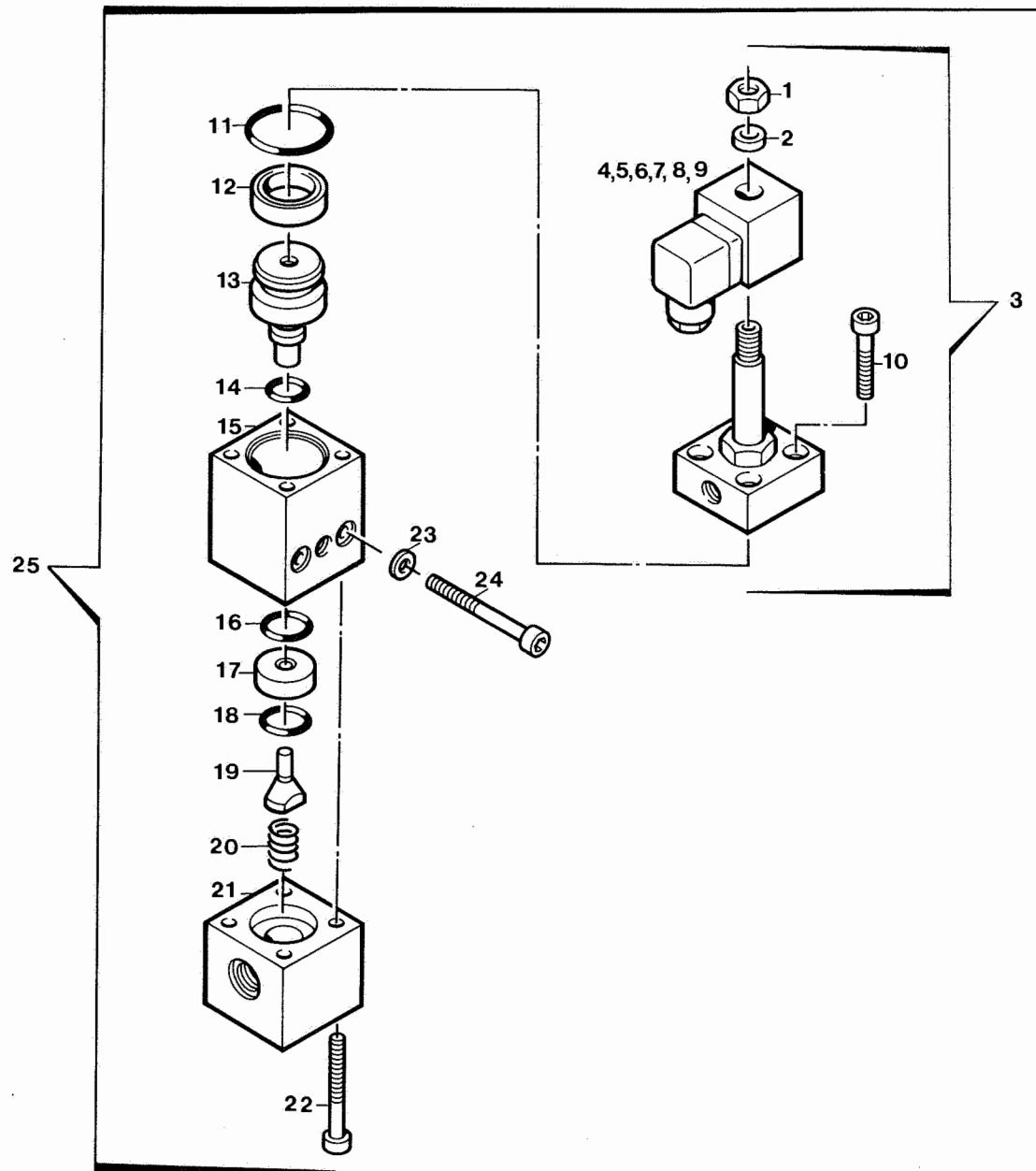



Ersatzteilsätze
Spare parts sets
Kits de pièces dét.

Bildtafel G21.1-6 Kondensatablaß ventil
Figure G21.1-6 Condensate drain valve
Planche G21.1-6 Bloc de purge des condensats

Änderung Nr.
Change No.
No. de changem.



Klasse Class Classe			Pos.	Bestell-Nr. Part No. No. de cde.	Benennung	Designation	Dénomination	Gewicht Weight Poids (kg)	Abmessungen Dimensions Dimensions
0	2	5							
			1		Sechskantmutter	Hex. nut	Ecrou hex.		
			2		Scheibe	Washer	Rondelle		
			3	058053-342	3/2 Wege-Magnetventil (o. Spule)	3/2-way solenoid valve (w/o coil)	Electrovanne 3/2 voies s. bob.	0.190	
	1	1	4	N 4180*	Hochtemperaturspule	High temperature coil	Bobine haute température	0.385	220 V, 50-60 Hz
	1	1	5	N 4181*	Hochtemperaturspule	High temperature coil	Bobine haute température	0.385	240 V, 50-60 Hz
	1	1	6	N 4183*	Hochtemperaturspule	High temperature coil	Bobine haute température	0.385	230 V, 50-60 Hz
	1	1	7	N 4182*	Hochtemperaturspule	High temperature coil	Bobine haute température	0.385	115 V, 50-60 Hz
	1	1	8	N 4185*	Hochtemperaturspule	High temperature coil	Bobine haute température	0.385	12 V=
	1	1	9	N 4186*	Hochtemperaturspule	High temperature coil	Bobine haute température	0.385	24 V=
	1	1	10	N 210	Innensechskantschraube	Allen screw	Vis à six pans creux	0.007	M 6 x 20 DIN 912
1	1	2	11	N 2720	O-Ring	O-ring	Joint torique	0.005	Ø 37 x 2
1	1	2	12	N 4177	Nutring	Sealing ring, chevron type	Bague	0.002	Ø 25x35x8x5
			13	60417-342	Ventilkolben	Valve piston	Piston	0.155	
1	1	2	14	N 3489	O-Ring	O-ring	Joint torique	0.001	Ø 10,77 x 2,62
			15	60414-342	Ventilkörper	Valve body	Corps du bloc	0.305	
1	1	2	16	N 2507	O-Ring	O-ring	Joint torique	0.001	Ø 18,77 x 1,78
			17	60419-342	Ventilsitz	Valve seat	Siège	0.009	
1	1	2	18	N 4178	O-Ring	O-ring	Joint torique	0.001	Ø 17,12 x 2,62
			19	60418-342	Dichtkegel	Sealing cone	Cône d'étanchéité	0.008	
	1	2	20	60600-640	Druckfeder	Pressure spring	Ressort	0.005	
			21	60415-342	Zwischenteil	Spacer	Pièce intermédiaire	0.260	
			22	N 3883	Innensechskantschraube	Allen screw	Vis à six pans creux	0.012	M 6 x 45 DIN 912
			23	N 102	Scheibe	Washer	Rondelle	0.001	Ø 6,4 DIN 125
			24	N 781	Innensechskantschraube	Allen screw	Vis à six pans creux	0.015	M 6 x 60 DIN 912
			25	060412-342	Kondensatablaßventil kpl.	Condensate drain valve assy.	Bloc de purge cpl.	1.375	
* Wahlweise - bei Bestellung Spannung und Frequenz angeben.					Optional - please specify voltage and frequency on order.	Optionnel - veuillez indiquer voltage et fréquence à la cde.			

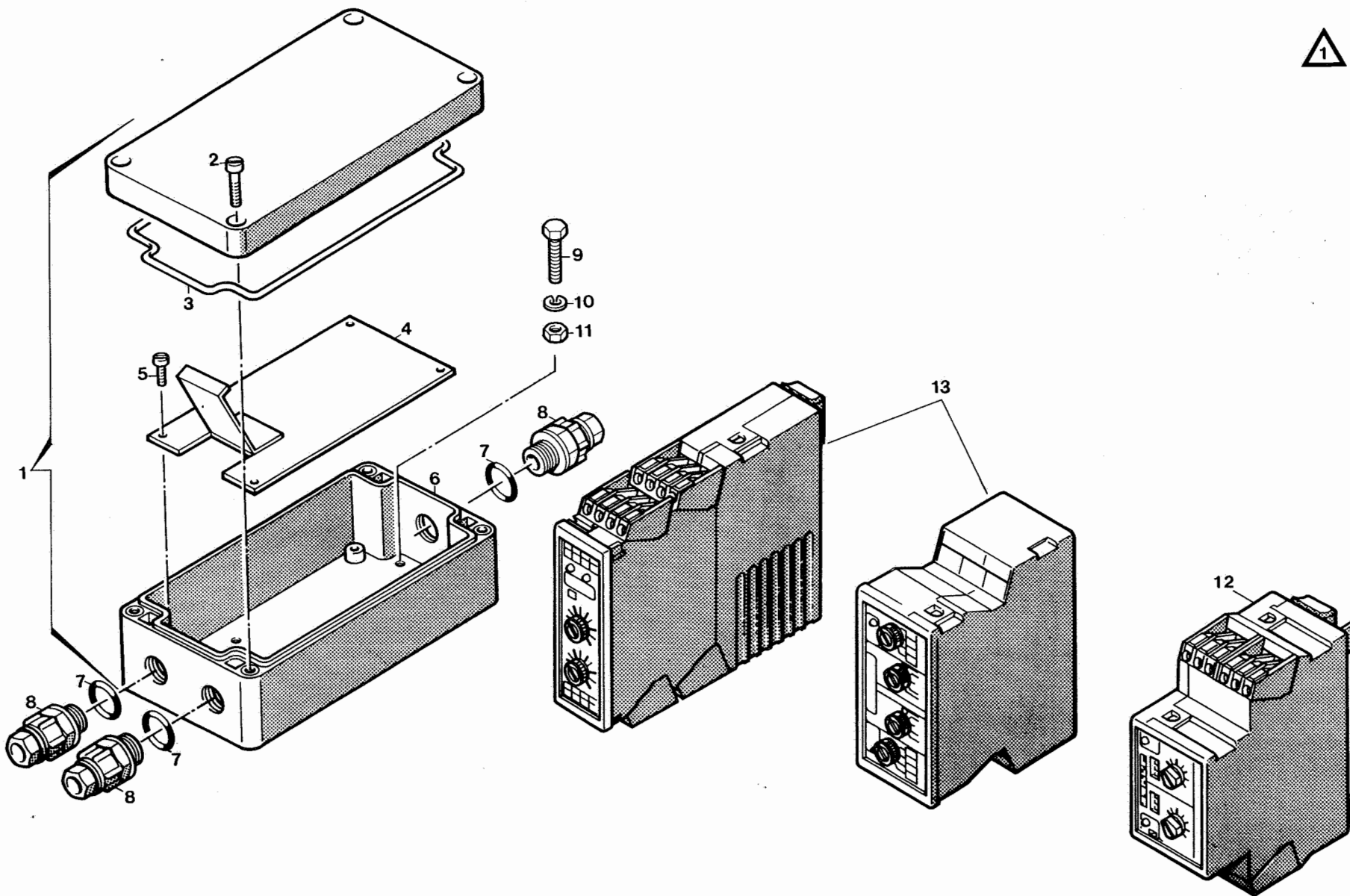



Ersatzteilsätze
Spare parts sets
Kits de pièces dét.

Bildtafel G21.1-7 Elektronische Laufschaaltwerke
Figure G21.1-7 Electrical timers
Planche G21.1-7 Minuterics électriques

Änderung Nr.
Change No.
No. de changem.



Klasse Class Classe			Pos.	Bestell-Nr. Part No. No. de cde.	Benennung	Designation	Dénomination	Gewicht Weight Poids (kg)	Abmessungen Dimensions Dimensions
0	2	5							
3	3	6	1	068518-992	Gehäuse kpl.	Housing assy.	Boîtier cpl.		
			2		Zylinderschraube	Cylindric head screw	Vis cylindrique		
			3		Dichtgummi	Gasket	Joint		
			4	68517-655	Montageplatte	Mounting plate	Plaque de montage		
			5		Zylinderschraube	Cylindric screw	Vis cylindrique		
			6	N 18280	Gehäuse	Housing	Boîtier		
			7		Dichtgummi	Gasket	Joint		
			8	N 3101	Kunststoffverschraubung	Screw type gland	Raccord plastique		PG 11
			9		Sechskantschraube	Hex. bolt	Vis hexagonale		M 4 x 12
			10		Federring	Lock Washer	Rondelle élastique		
			11		Sechskantmutter	Hex. nut	Écrou hex.		M 4
			12	N 18484	Pause und Impuls einstellbar: 0-10 Std. Laufschaaltwerk	Pulse and Pause adjustable: 0-10 hours Electrical timer	Marche et arrêt ajustables: 0-10 heures Minuterie électrique		24-240 V, 45-65 Hz
			13	N 16202 N 18410 N 18411 N 18781 N 18412 N 18367	Pause und Impuls einstellbar: wahlweise 30 min./30 s Laufschaaltwerk, elektronisch Laufschaaltwerk, elektronisch Laufschaaltwerk, elektronisch Laufschaaltwerk, elektronisch Laufschaaltwerk, elektronisch Laufschaaltwerk, elektronisch	Pulse and Pause adjustable: optional 30 min./30 s Electrical timer Electrical timer Electrical timer Electrical timer Electrical timer Electrical timer	Marche et arrêt ajustable: au choix 30 min./30 s Minuterie électrique Minuterie électrique Minuterie électrique Minuterie électrique Minuterie électrique Minuterie électrique		220 V, 50-60 Hz 115 V, 50-60 Hz 240 V, 50-60 Hz 12 V= 24 V= 24 V, 50-60 Hz

