

Ersatzteilliste
Spare parts catalogue
Liste des pièces

G4.6 Filtersystem P100
G4.6 Filter system P100
G4.6 Système de filtration P100

BAUER
KOMPRESSOREN

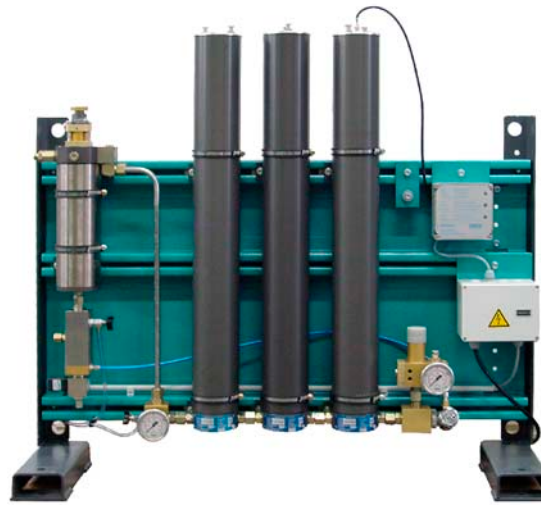

Baugruppe	Assembly	Assemblage	Bild/Fig.
Filtersystem P100	Filter system P100	Système de filtration P100	G4.6- 1
Sicherheitsventil	Safety valve	Soupape de sûreté	G4.6- 2
Öl- und Wasserabscheider	Oil and water separator	Séparateur d'huile et d'eau	G4.6- 3
Rückschlagventil kpl.	Non-return valve assy.	Soupape anti-retour cpl.	G4.6- 4
Druckhalte-/Rückschlagventil	Pressure maintaining/non-return valve	Soupape de maintien de pression et clapet anti-retour	G4.6- 5
Filtern	Filters	Filtres	G4.6- 6
CO-Filter	CO-Filter	Filtre CO	G4.6- 7
Kondensat-Ablabautomatik	Condensate drain system	Purge automatique des condensats	G4.6- 8
Drucküberwachung	Pressure control	Surveillance de la pression	G4.6- 9

Änder.-Nr. Change no. No. de change	Datum Date	Änderung	Change	Changement
0	18.10.85	Grundausgabe	Basic edition	Edition de base
1	18.04.86	Knebelschraube, Halteblech	Tommy screw, bracket	Robinet, fixation
2	17.02.88	Konsole, Druckhalteventil	Console, pressure maintaining/non-return valve	Console, soupape anti-retour et maintien de pression
3	06.08.90	Öl- und Wasserabscheider, Entlüftungsventil	Oil and water separator, venting valve	Séparateur pour SECURUS, clapet de décharge
4	01.05.01	COMP-TRONIC-Sensorkopf	COMP-TRONIC sensor head	Capteur COMP-TRONIC
5	01.08.02	Neue Filterbehälter	New filters	Nouveaux filtres
6	01.10.06	Ä.-M. 8323	Modification no. 8323	Modification no. 8323

Wichtige Hinweise für Teilebestellung:

Bestell-Nr., die mit der Ziffer 0 beginnen, bezeichnen Baugruppen, die komplett geliefert werden. Teile ohne Bestell-Nr. sind nur zur Information für die Montage aufgeführt. Sie sind nicht als Ersatzteil erhältlich. Bei Ersatzteilbestellungen erwarten Sie unsere richtige Lieferung; deshalb benötigen wir von Ihnen folgende Angaben (siehe unten gezeigtes Typenschild):

1. Modellbezeichnung, Fabrik-Nr. sowie Fertigungsstand von Anlage/Block
2. Stückzahlen
3. Benennung und Best.-Nr. des gewünschten Teils

Bestell-Beispiel:

Für Kompressorblock ...
Fabrik-Nr. 524-0528/1/2 drei Dichtungen
8263-090

Important notes for spare parts orders:

Part nos. beginning with digit 0 indicate parts available as complete assemblies. Parts without part no. are indicated for assembly reference, only. These parts are not available as single parts. When placing an order for spare parts, please give the following items so as to ensure our correct delivery (see identification plate shown below):

1. Model, serial no. as well as design standard of unit/block
2. Quantity required
3. Name and part no.

Example for order:

For compressor block ...
serial no. 524-0528/1/2, three gaskets
8263-090

Avis important pour la commande de pièces:

Les nos. de commande commençant par le chiffre 0 indiquent les pièces livrées au complet. Les pièces sans no. de commande sont indiquées uniquement pour information de montage. Elles ne sont pas livrées individuellement. Pour que la livraison de pièces de rechange corresponde à la commande, veuillez bien nous fournir les données suivantes (voir plaque d'identité ci-dessous):

1. Modèle, no. de série et standard de construction de bloc compresseur/groupe
2. Quantité désirée
3. Dénomination et no. de commande de la pièce désirée

Exemple de commande:

Pour bloc compresseur ...
no. de série 524-0528/1/2, trois joints no. de cde. 8263-090



Wartungssätze

- a =Wartungssatz 500 h
- b =Wartungssatz 1000 h
- c =Wartungssatz 2000 h



Maintenance kit

- a = Maintenance kit 500 h
- b = Maintenance kit 1000 h
- c = Maintenance kit 2000 h



Kits de pièces d'entretien :

- a = Kit d'entretien 500 h
- b = Kit d'entretien 1000 h
- c = Kit d'entretien 2000 h

In den Spalten sind die im entsprechenden Satz enthaltenen Teile angekreuzt. Bitte beachten, daß die höheren Sätze die untergeordneten nicht beinhalten, d.h. für eine 2000-Stunden-Wartung wird 1x Satz a, 1x Satz b und 1x Satz c benötigt.

The columns contain the parts that are included in the respective parts set. Please note that the higher graded kits do not include the lower ones, i.e. for a 2000 hours maintenance, one kit a, one kit b plus one kit c are required.

Les pièces contenues dans les kits correspondants sont marquées d'une croix dans les colonnes. Veuillez observer que les kits supérieurs ne contiennent pas les kits subordonnés, c'est-à-dire pour un entretien de 2000 heures il faut avoir 1x kit a, 1x kit b et 1x kit c.

**Anmerkungen zur Identifikation:
Remarks for identification:
Remarques pour l'identification:**

Modell/Model/Modèle		Fabrik-Nr./Serial no./Numéro de série	
<input type="checkbox"/>		<input type="checkbox"/>	
Volumenstrom m ³ /min	<input type="checkbox"/>	Jahr Year	<input type="checkbox"/>
Free air delivery Scfm	<input type="checkbox"/>	n/min. r.p.m.	<input type="checkbox"/>
Betriebsüberdruck bar	<input type="checkbox"/>	kW	<input type="checkbox"/>
Max. working press. psig	<input type="checkbox"/>	CE	<input type="checkbox"/>
		Fertigungsstand / Modification no. / No. de modification	
		Anlage/Unit/Groupe	
		Kompressorblock/ Compressor block/ Bloc compresseur	



ACHTUNG

Nur Schrauben und Stiftschrauben der Qualität 8.8 verwenden!



ATTENTION

Use only screws and studs in quality 8.8! This quality is equivalent to SAE J 429 d grade 5.



ATTENTION

N'utiliser que des vis et des goujons filetés de la qualité 8.8!

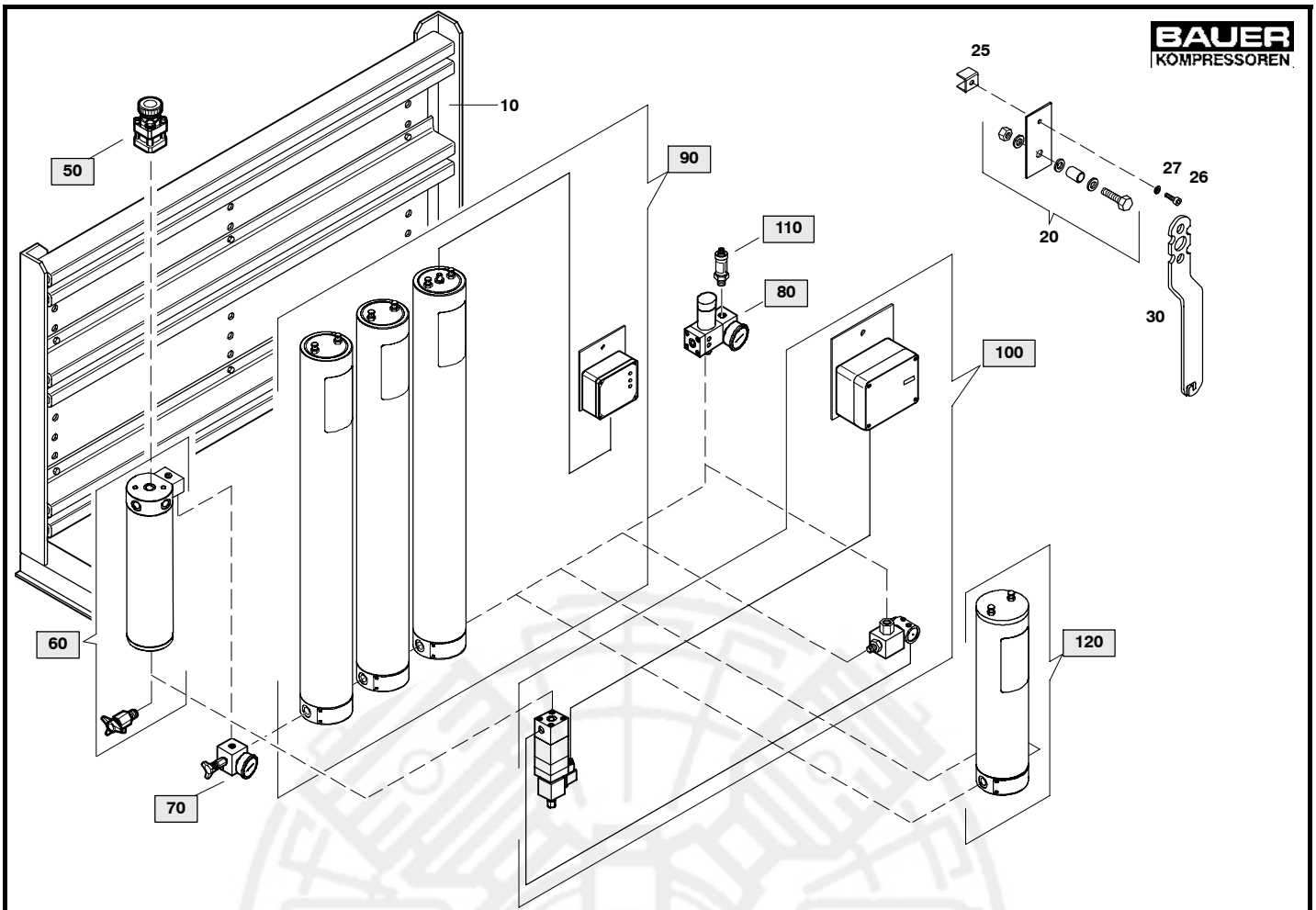
G4.6- 1

Wartungssätze
Maintenance kits
Kits d'entretien

Baugruppe	P100/350	Filtersystem P100
Assembly	P100/350	Filtersystem P100
Assemblage	P100/350	Système de filtration P100

Klasse/ Class/ Classe			Pos.	Bestell-Nr. Part No. No. de cde.	Anz. Qty. Qté.	Benennung	Designation	Dénomination
a	b	c						
			10	077881	1	Rahmen	Frame	Cadre
			20	78264	1	Halterung für Filterschlüssel	support for filter key	support des clés
			25	090719	1	Befestigung	fitting	fixation
			26	N19552	1	Zylinderschraube	allen screw	vis allen
			27	N58	1	Scheibe	washer	rondelle
			30	60074	1	Filterschlüssel	Filter key	Clé de filtre
			50	80859	1	Sicherheitsventil	Safety valve	Soupape de sûreté
			60	78382	1	Öl- und Wasserabscheider kpl.	Oil and water separator assy.	Séparateur d'huile et d'eau cpl.
			70	78748	1	Rückschlagventil kpl.	Non-return valve assy.	Soupape anti-retour cpl.
			80	060510	1	Druckhalte-/Rückschlagventil kpl.	Pressure maintaining/non-return valve assy.	Soupape de maintien de pression/anti-retour cpl.
			90	78378/80/81	1	Filterbehälter	Filter housing	Corps du filtre
			100	78385*	1	Kondensat-Ablaufautomatik kpl.	Condensate drain unit assy.	Purge automatiq. des condensats cpl.
			110	80881*	1	Drucküberwachung	Pressure control	Surveillance de la pression
			120	78384*	1	CO-Filter	CO-filter	Filtre CO

*

Option

Option

Option

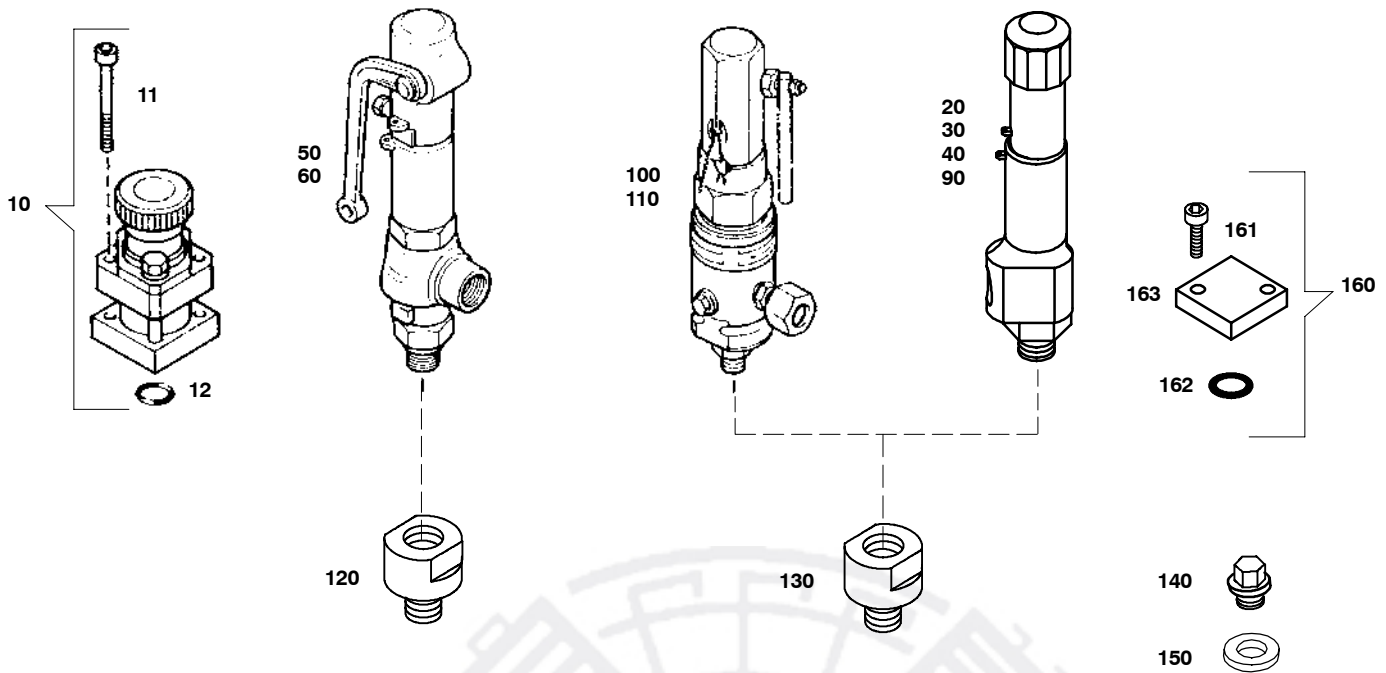

090214/09/96

 Ersatzteilsätze
 Spare parts sets
 Kits de pièces dét.

 Baugruppe 80859
 Assembly 80859
 Assemblage 80859

 Sicherheitsventile
 Safety valves
 Soupapes de sûreté

G4.6- 2

Klasse/ Class/ Classe			Pos.	Bestell-Nr. Part No. No. de cde.	Anz. Qty. Qté.	Benennung	Designation	Dénomination
0	2	5						
			10	059410	1	Sicherheitsventil 100-365bar	safety valve 100-365bar	soupape de sûreté 100-365bar
			11	N1776	2	Zylinderschraube	allen screw	vis six pans creux
			12	N4882	1	O-Ring	o-ring	joint torique
			20	N26253	1	Sicherheitsventil 68-93bar	safety valve 68-93bar	soupape de sûreté 68-93bar
			30	N26252	1	Sicherheitsventil 93-121bar	safety valve 93-121bar	soupape de sûreté 93-121bar
			40	N26233	1	Sicherheitsventil 121-180bar	safety valve 121-180bar	soupape de sûreté 121-180bar
			50	N27387	1	Sicherheitsventil 180-215bar	safety valve 180-215bar	soupape de sûreté 180-215bar
			60	N27394	1	Sicherheitsventil 215-330bar	safety valve 215-330bar	soupape de sûreté 215-330bar
			90	N27846	1	Sicherheitsventil 330-370bar	safety valve 330-370bar	soupape de sûreté 330-370bar
			100	N16778	1	Sicherheitsventil 316-390bar	safety valve 316-390bar	soupape de sûreté 316-390bar
			110	N17066	1	Sicherheitsventil 391-525bar	safety valve 391-525bar	soupape de sûreté 391-525bar
			120	N18619	1	Gewinde-Reduzierstutzen	reducing coupling	raccord réducteur
			130	N3833	1	Gewinde-Reduzierstutzen	reducing coupling	raccord réducteur
			140	N204	1	Verschlussschraube	screw plug	vis d'obturation
			150	N842	1	Dichtring	gasket	joint
			160	090318	1	Verschlußflansch kpl.	flange assy.	bride cpl.
			161	N61	2	Zylinderschraube	allen screw	vis six pans creux
			162	N4882	1	O-Ring	o-ring	joint torique
			163	90237	1	Verschlußflansch	flange	bride

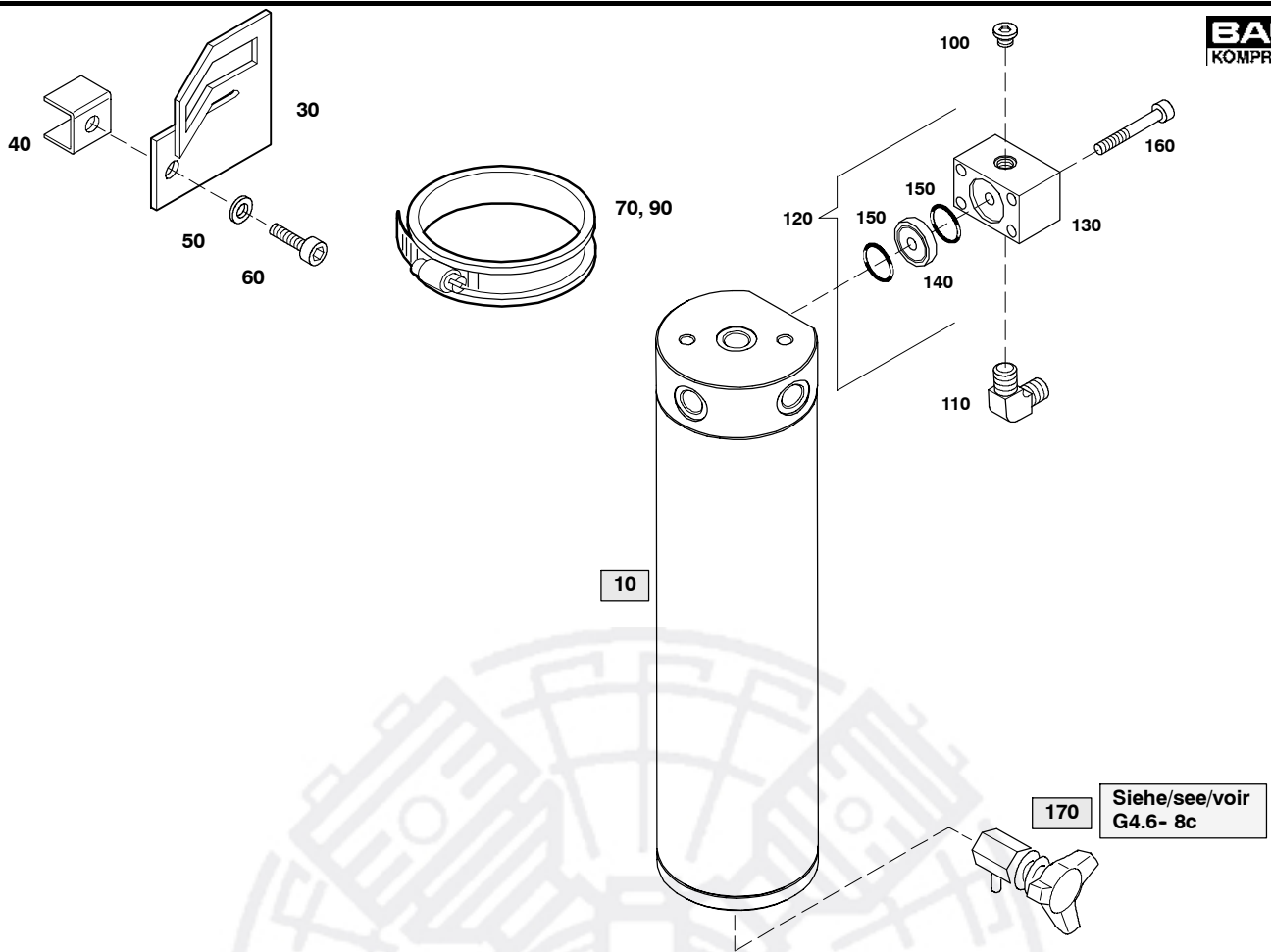
 Wartungssätze
 Maintenance kits
 Kits d'entretien

 Baugruppe 78382
 Assembly 78382
 Assemblage 78382

 Öl- und Wasserabscheider kpl.
 Oil and water separator assy.
 Séparateur d'huile et d'eau cpl.

G4.6- 3

Klasse/ Class/ Classe			Pos	Bestell-Nr. Part No. No. de cde.	Anz Qty. Qté.	Benennung	Designation	Dénomination
a	b	c						
			10	83111-EU	1	Öl- und Wasserabscheider PN350	oil and water separator PN350	Séparateur d'huile et d'eau PN350
			30	78549	2	Halterung	support	fixation
			40	090719	2	Befestigung	fitting	fixation
			50	N19552	2	Zylinderschraube	allen screw	vis allen
			60	N58	5	Scheibe	washer	rondelle
			70	N15499	2	Schlauchschele D90-110 mm	clamp D90-110 mm	collier D90-110 mm
			90	N15500	2	Gummiprofil	rubber profile	bande caoutchouc
			100	N20281	1	W-Einschraubstutzen	elbow coupling	coude
			110	N16394	6	Verschlußschraube	screw plug	bouchon
			120	090126	1	Vierkant kpl.	adaptor block assy.	bloc adaptateur cpl.
			130	90059	1	Vierkant	adaptor block	bloc adaptateur
			140	63998	1	Nippel	Nipple	entretoise
			150	N4178	2	O-Ring	o-ring	joint torique
			160	N19538	4	Zylinderschraube	allen screw	vis allen
			170	011430	1	Ablaßhahn	drain tape	robinet de purge

83111-EU

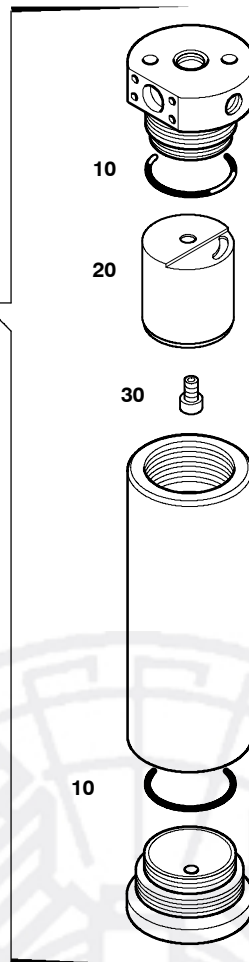

Wartungssätze
Maintenance kits
Kits d'entretien

Baugruppe 83111-EU Öl- und Wasserabscheider
Assembly 83111-EU Oil and water separator
Assemblage 83111-EU Séparateur d'huile et d'eau

G4.6- 3a

Klasse/ Class/ Classe			Pos.	Bestell-Nr. Part No. No. de cde.	Anz. Qty. Qté.	Benennung	Designation	Dénomination
a	b	c						
X			10	N4586	2	O-Ring	o-ring	joint torique
			20	84823	1	Schutzkappe	protecting bell	cloche
			30	81643	1	Hohlschraube	hole screw	vis creuse

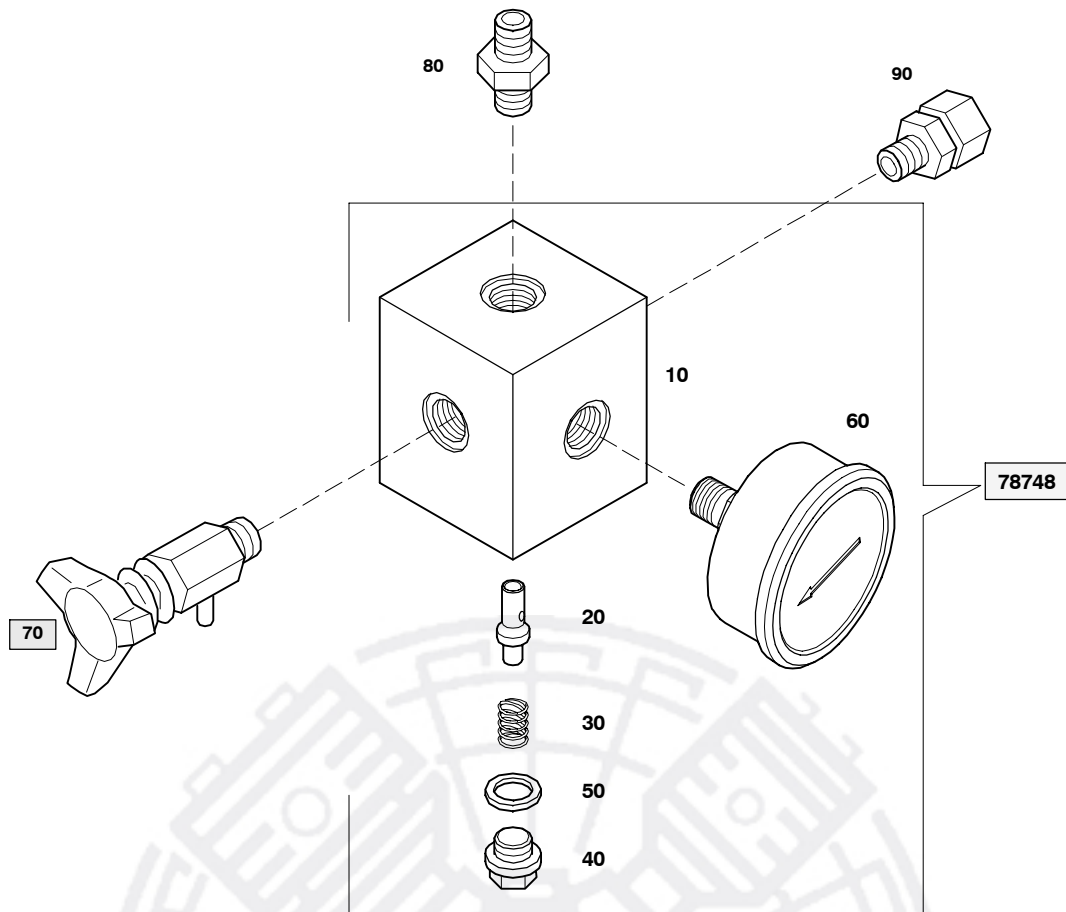

Wartungssätze
Maintenance kits
Kits d'entretien

Baugruppe 78748
Assembly 78748
Assemblage 78748

Rückschlagventil kpl.
Non-return valve assy.
Soupape anti-retour cpl.

G4.6- 4

Klasse/ Class/ Classe			Pos.	Bestell-Nr. Part No. No. de cde.	Anz. Qty. Qté.	Benennung	Designation	Dénomination
a	b	c						
			10	78746	1	Ventilkörper	valve body	corps du soupape
			20	78750	1	Ventilkolben	valve piston	piston du soupape
			30	N20699	1	Druckfeder	spring	ressort
			40	N204	1	Verschlußschraube	plug	bouchon fileté
			50	N4499	1	USIT-Ring	USIT ring	joint USIT
			60	N22330	1	Manometer	pressure gauge	manomètre

			70	011430	1	Ablaßhahn	drain tap	robinet
			80	N20280	1	G-Einschraubstutzen	coupling	raccord
			90	N15922	1	G-Einschraubstutzen	coupling	raccord

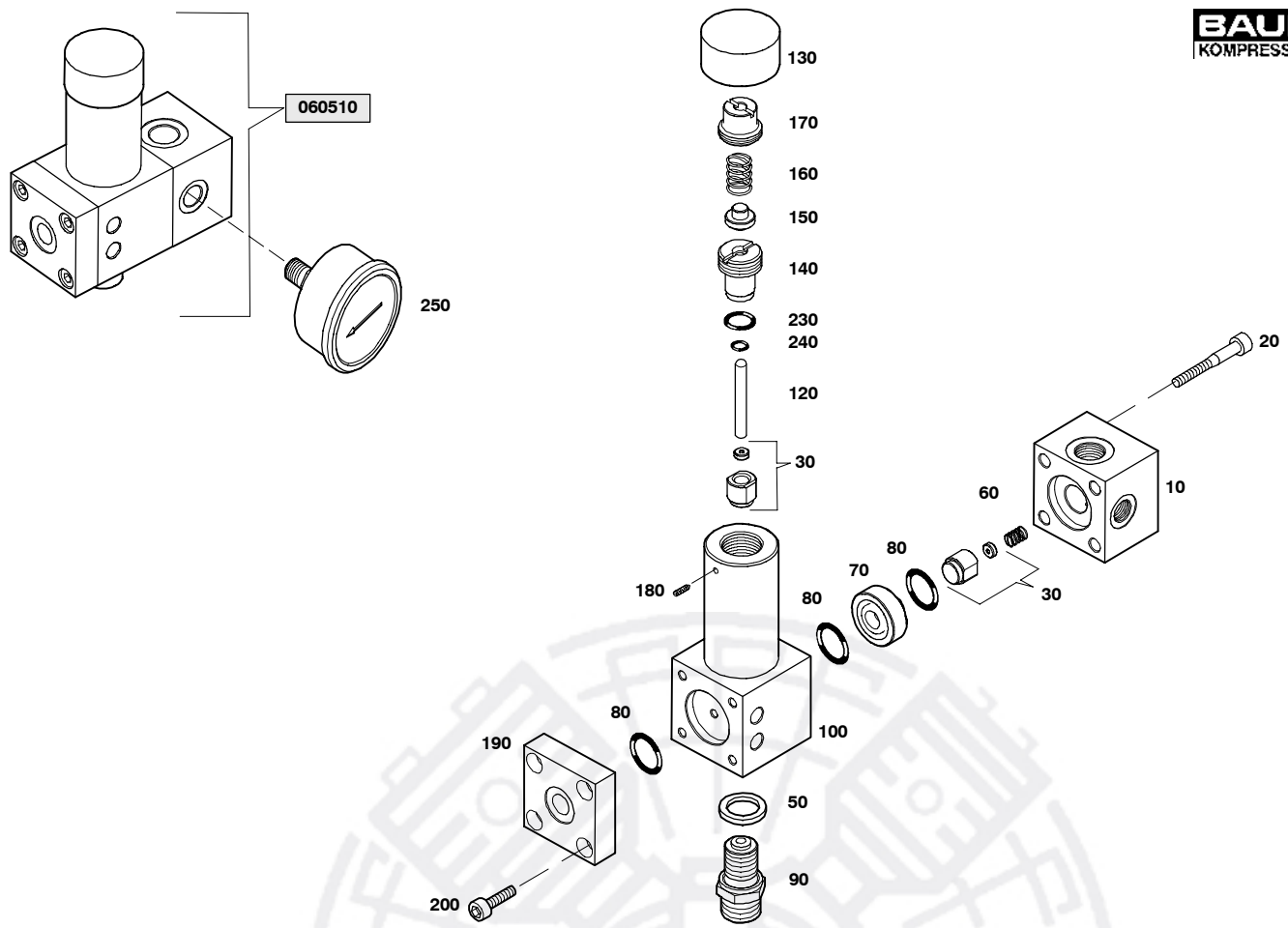



Wartungssätze
Mainenance sets
Kits de maintenance

Baugruppe 060510 **Druckhalte-/Rückschlagventil, 400 bar; DN5**
Assembly 060510 **Pressure maintaining/non-return valve, 400 bar, DN5**
Assemblage 060510 **Soupape de maintien de pression/anti-retour, 400 bar, DN5**

G4.6- 5

Klasse/ Class/ Classe			Pos.	Bestell-Nr. Part No. No. de cde.	Anz. Qty. Qté.	Benennung	Designation	Dénomination
a	b	c						
			10	56672	1	Ventilkörper RSV	valve housing	corps de soupape
			20	N19539	4	Zylinderschraube	allen screw	vis allen
			30	056674	2	Ventilkolben kpl.	valve piston assy.	piston de soupape cpl.
			50	N4499	1	Usit-Ring	Usit ring	joint Usit
			60	2623	1	Druckfeder	spring	ressort
			70	63843	1	Ventilsitz RSV	valve seat	siège de soupape
			80	N4178	3	O-Ring	o-ring	joint torique
			90	60511	1	Ventilsitz DHV	valve seat	siège de soupape
			100	56671	1	Ventilkörper DHV	valve housing	corps de soupape
			120	77245	1	Zylinderstift	cylinder pin	goupille
			130	N16773	1	Kappe	cover	couvercle
			140	77246	1	Verschraubung f. DHV 056705	coupling	raccord
			150	56675	1	Aufnahme Feder	spring seat	siège de ressort
			160	2623	1	Druckfeder	pressure spring	ressort de pression
			170	57517	1	Einstellschraube	setting screw	vis de réglage
			180	N4465	1	Gewindestift	threaded pin	vis sans tête
			190	56736	1	Blindflansch	blind flange	bride aveugle
			200	N19534	4	Zylinderschraube	allen screw	vis allen
			230	N24927	1	O-Ring	o-ring	joint torique
			240	N25503	1	O-Ring	o-ring	joint torique

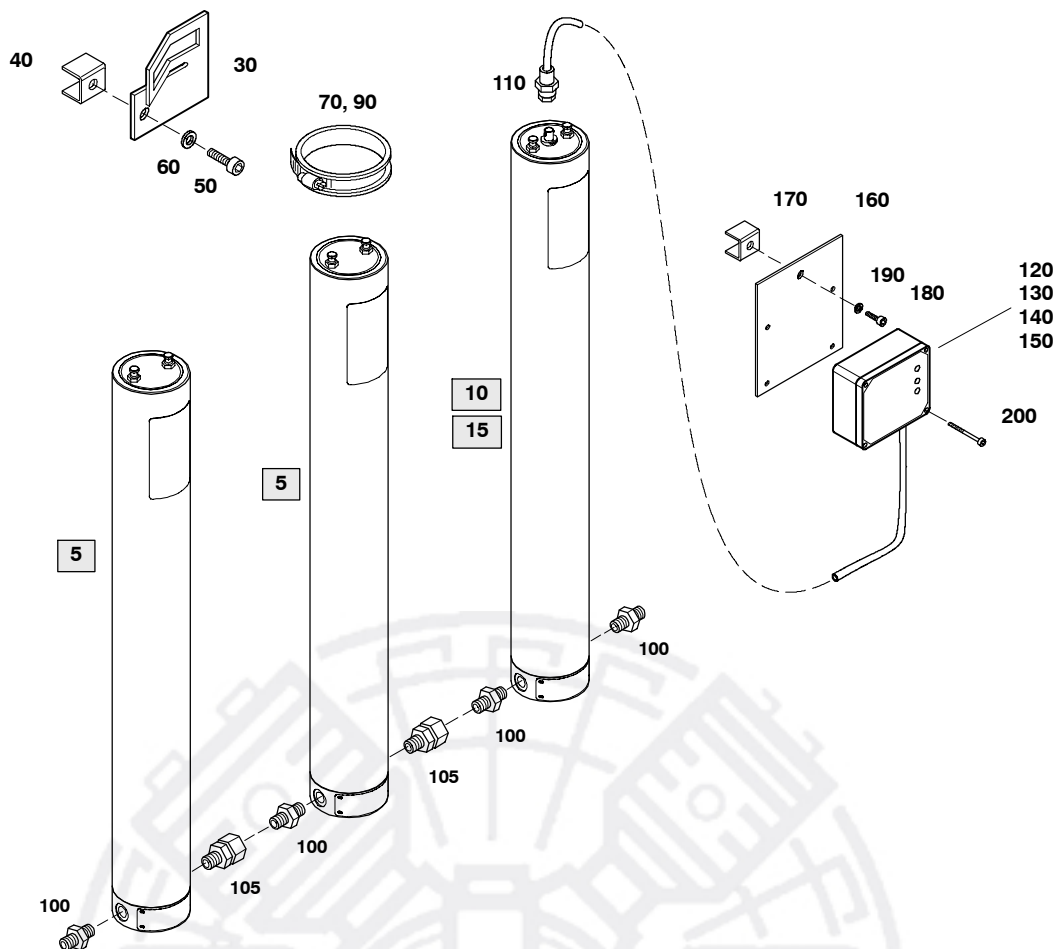
			250	N22330	1	Manometer	manometer	manomètre
--	--	--	-----	--------	---	-----------	-----------	-----------

Wartungssätze
Mainenance kits
Kits d'entretien
Baugruppe 78378/80/81
Assembly 78378/80/81
Assemblage 78378/80/81

Filterbehälter PN 350
Filter housing PN 350
Filtre PN 350
G4.6- 6

Klasse/ Class/ Classe			Pos.	Bestell-Nr. Part No. No. de cde.	Anz. Qty. Qté.	Benennung	Designation	Dénomination
a	b	c						
			5	061082-EU	1	Filter standard	filter standard	filtre standard
			10	061224-EU	1	Filter für Securus-Meldegerät	filter for Securus indicator unit	filtre pour alarme Securus
			15	090970-EU	1	Filter für Kompressorsteuerung-Anschluß	filter for compressor control connection	filtre pour connexion avec commande de compresseur
			30	78549	6	Halterung	support	fixation
			40	090719	6	Befestigung	fitting	fixation
			50	N19552	6	Zylinderschraube	allen screw	vis allen
			60	N58	6	Scheibe	washer	rondelle
			70	N15499	6	Schlauchschelle D90-110 mm	clamp D90-110 mm	collier D90-110 mm
			90	N15500	6	Gummiprofil	rubber profile	bande caoutchouc
			100	N20280	3	G-Einschraubstutzen	coupling	coupling
			105	N15922	2	G-Einschraubstutzen (EGES)	coupling	coupling
			110	N21762-S01	1	Anschlußleitung kpl. (für 090970-EU)	cable assy. (for 090970-EU)	câble cpl. (pour 090970-EU)
			120	N15094	1	SECURUS-Meldegerät (190-250 VAC; 50-60 Hz)	SECURUS indicator unit (190-250 VAC; 50-60 Hz)	alarme Securus (190-250 VAC; 50-60 Hz)
			130	N15095	1	SECURUS-Meldegerät (110-127 VAC; 50-60 Hz)	SECURUS indicator unit (110-127 VAC; 50-60 Hz)	alarme Securus (110-127 VAC; 50-60 Hz)
			140	N18362	1	SECURUS-Meldegerät (24 VAC; 50-60 Hz)	SECURUS indicator unit (24 VAC; 50-60 Hz)	alarme Securus (24 VAC; 50-60 Hz)
			150	N15096	1	SECURUS-Meldegerät (12-24 VDC)	SECURUS indicator unit (12-24 VDC)	alarme Securus (12-24 VDC)
			160	78387	1	Halterung	Bracket	Fixation
			170	090719	1	Befestigung	fitting	fixation
			180	N19552	1	Zylinderschraube	allen screw	vis allen
			190	N58	1	Scheibe	washer	rondelle
			200	N4345	4	Zylinderschraube	allen screw	vis allen

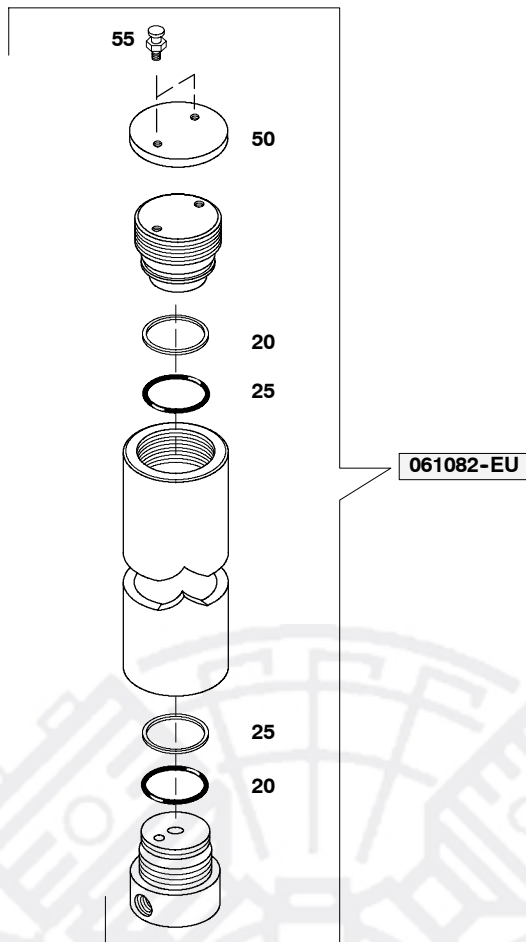

Wartungssätze
Mainenance kits
Kits d'entretien
Baugruppe 061082-EU **Standard Filterbehälter PN 350**
Assembley 061082-EU **Standard Filter housing PN 350**
Assemblage 061082-EU **Filtre standard PN 350**
G4.6- 6a

Klasse/ Class/ Classe			Pos.	Bestell-Nr. Part No. No. de cde.	Anz. Qty. Qté.	Benennung	Designation	Dénomination
a	b	c						
X			20	N4736	2	Stützring	back-up ring	bague d'appui
X			25	N4735	2	O-Ring	o-ring	joint torique
			30	90761	1	Fabrikschild	Ident. plate	plaque d'identification
			35	N3334	1	Niete	semitubular rivet	rivet semi-tubulaire
			40	N3333	3	Blindniete	pop rivet	rivet aveugle
			45	91024	1	Klebeschild	sticker	auto-collant
			50	61237	1	Schutzdeckel	protective cover	couvercle protecteur
			55	12293	2	Schraube	screw	vis

Filterpatronen / Filter cartridges / Cartouches de filtre

Bestell-Nr. Part No. No. de cde.	Patronenfüllung ^{a)} Cartridge contents ^{a)} Matière filtrante ^{a)}		
	H ₂ O	Oil Huile	CO CO CO
058825	●		
058826	●	●	

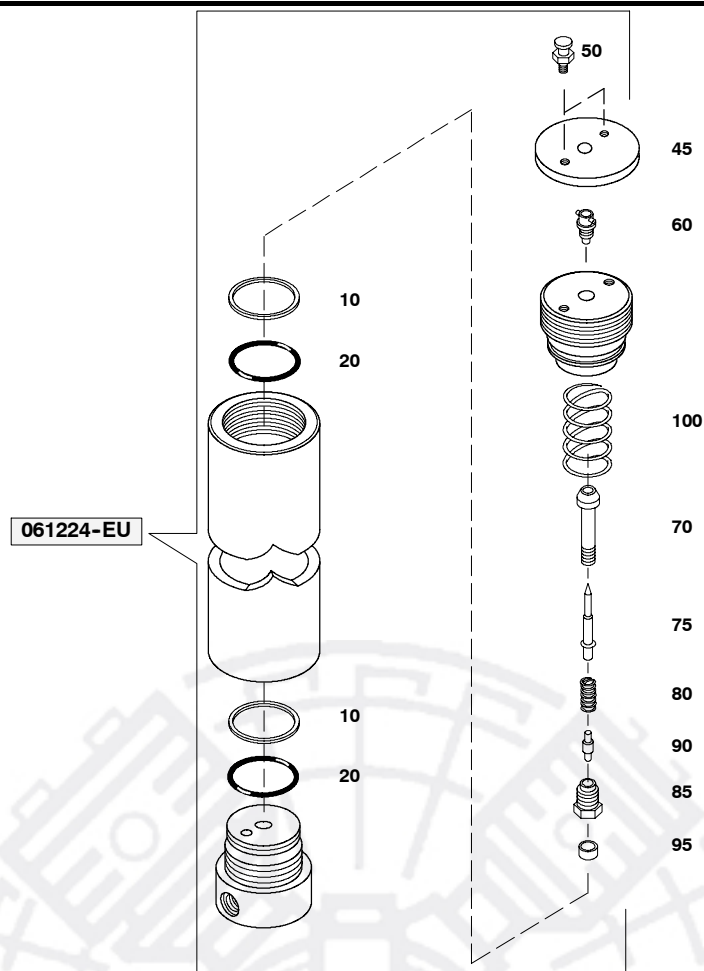
^{a)} AC = Aktivkohle, MS = Molekularsieb, HP = Hopcalite, SEC = Securus
 AC = Activated charcoal, MS = Molecular sieve, HP = Hopcalite, SEC = Securus
 AC = Charbon actif, MS = Tamis moléculaire, HP = Hopcalite, SEC = Securus

Wartungssätze
Mainenance kits
Kits d'entretien
Baugruppe
Assembly
Assemblage
061224-EU
061224-EU
061224-EU
Filterbehälter für Securus-Meldegerät
Filter housing for Securus device
Filtre pour alarme Securus
G4.6- 6b

Klasse/ Class/ Classe			Pos.	Bestell-Nr. Part No. No. de cde.	Anz. Qty. Qté.	Benennung	Designation	Dénomination
a	b	c						
X			10	N4736	2	Stützring	back-up ring	bague d'appui
X			20	N4735	2	O-Ring	o-ring	joint torique
			30	78528	1	Fabrikschild	ident. plate	plaque d'identification
			35	N3334	1	Niete	semitubular rivet	rivet semi-tubulaire
			40	N3333	3	Blindniet	pop rivet	rivet aveugle
			45	60135	1	Schutzdeckel	protecting cover	couvercle-protecteur
			50	12293	2	Schraube	fastening screw	vis de fixation
			55	91025	1	Klebeschild	sticker	autocollant
			60	59850	1	HF-Einbaubuchse	RF socket	connecteur H.F.
			70	59851	1	Bolzen	screw	boulon
			75	59853	1	Stift	pin	pointeau
			80	60062	1	Druckfeder	spring	ressort
			85	59852	1	Schraube	screw	vis
			90	59854	1	Stift	pin	pointeau
			95	59855	1	Mutter	nut	écrou
			100	2181	1	Druckfeder	spring	ressort

Filterpatronen / Filter cartridges / Cartouches de filtre

Bestell-Nr. Part No. No. de cde.	SECURUS	H ₂ O	Oil Huile	Patronenfüllung ^{a)} Cartridge contents ^{a)} Matière filtrante ^{a)}
060036	●	●	●	MS-MS-AC-MS/SEC

^{a)} AC = Aktivkohle, MS = Molekularsieb, HP = Hopcalite, SEC = Securus
 AC = Activated charcoal, MS = Molecular sieve, HP = Hopcalite, SEC = Securus
 AC = Charbon actif, MS = Tamis moléculaire, HP = Hopcalite, SEC = Securus

090970-EU

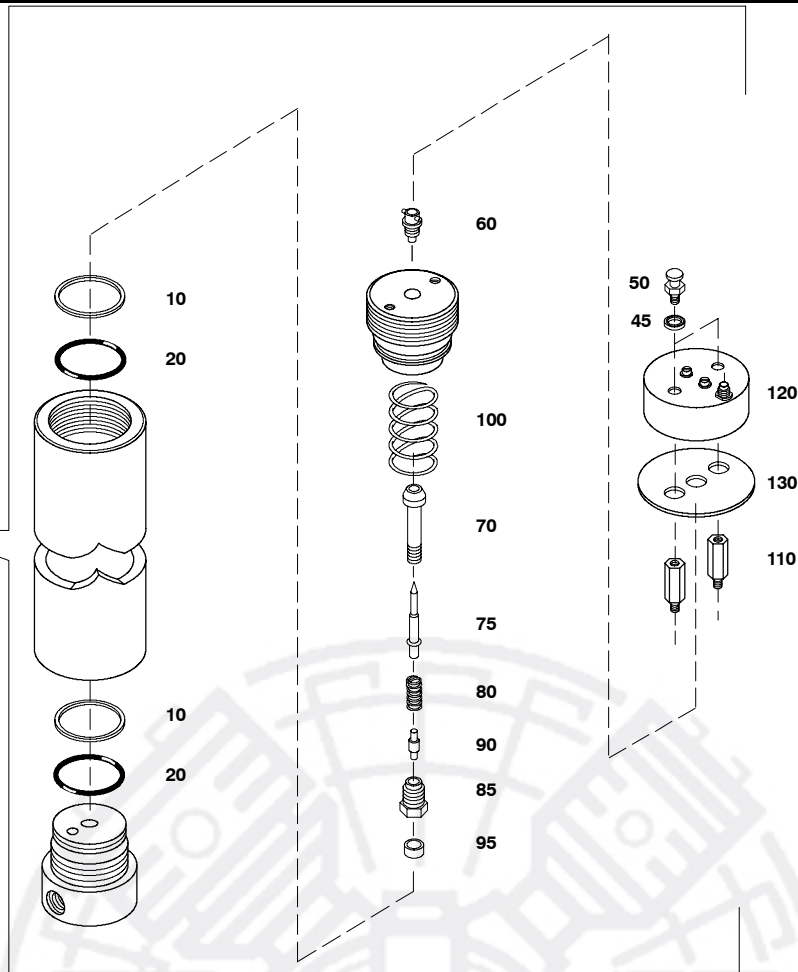

Wartungssätze
Mainenance kits
Kits d'entretien

Baugruppe 090970-EU
Assembly 090970-EU
Assemblage 090970-EU

Filterbehälter mit Steuerung-Anschluß
Filter housing with control connection
Filtre avec connexion pour commande

G4.6- 6c

Klasse/ Class/ Classe			Pos.	Bestell-Nr. Part No. No. de cde.	Anz. Qty. Qté.	Benennung	Designation	Dénomination
a	b	c						
X			10	N4736	2	Stutzring	back-up ring	bague d'appui
X			20	N4735	2	O-Ring	o-ring	joint torique
			30	78528	1	Fabricschild	ident. plate	plaque d'identification
			35	N3334	1	Niete	semitubular rivet	rivet semi-tubulaire
			40	N3333	3	Blindniet	pop rivet	rivet aveugle
			45	N20648	2	USIT-Ring	USIT ring	joint USIT
			50	12293	2	Schraube	fastening screw	vis de fixation
			55	91025	1	Klebeschild	sticker	autocollant
			60	59850	1	HF-Einbaubuchse	RF socket	connecteur H.F.
			70	59851	1	Bolzen	screw	boulon
			75	59853	1	Stift	pin	pointeau
			80	60062	1	Druckfeder	spring	ressort
			85	59852	1	Schraube	screw	vis
			90	59854	1	Stift	pin	pointeau
			95	59855	1	Mutter	nut	écrou
			100	2181	1	Druckfeder	spring	ressort
			110	90765	2	Sechskant	distance bolt	boulon d'écartement
			120	090570	1	SECURUS	SECURUS	SECURUS
			130	90715	1	Dichtung	gasket	joint

Filterpatronen / Filter cartridges / Cartouches de filtre

Bestell-Nr. Part No. No. de cde.	SECURUS	H ₂ O	Oel Oil Huile	Patronenfüllung ^{a)} Cartridge contents ^{a)} Matière filtrante ^{a)}
060036	●	●	●	MS-MS-AC-MS/SEC

a) AC = Aktivkohle, MS = Molekularsieb, HP = Hopcalite, SEC = Securus
AC = Activated charcoal, MS = Molecular sieve, HP = Hopcalite, SEC = Securus
AC = Charbon actif, MS = Tamis moléculaire, HP = Hopcalite, SEC = Securus

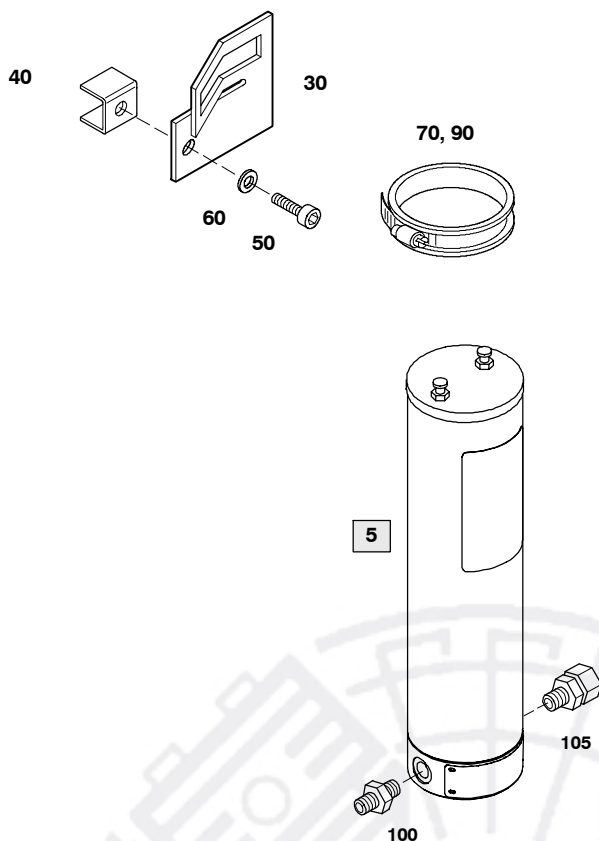

Wartungssätze
 Maintenance kits
 Kits d'entretien

Baugruppe 783384 CO-Filter
 Assembly 783384 CO-Filter
 Assemblage 783384 Filtre CO

G4.6- 7

Klasse/ Class/ Classe			Pos.	Bestell-Nr. Part No. No. de cde.	Anz. Qty. Qté.	Benennung	Designation	Dénomination
a	b	c						
			5	061081-EU	1	Filter standard	filter standard	filtre standard
			30	78549	4	Halterung	support	fixation
			40	090719	4	Befestigung	fitting	fixation
			50	N19552	4	Zylinderschraube	allen screw	vis allen
			60	N58	4	Scheibe	washer	rondelle
			70	N15499	4	Schlauchschelle D90-110 mm	clamp D90-110 mm	collier D90-110 mm
			90	N15500	4	Gummiprofil	rubber profile	bande caoutchouc
			100	N20280	3	G-Einschraubstutzen	coupling	coupling
			105	N15922	2	G-Einschraubstutzen (EGES)	coupling	coupling

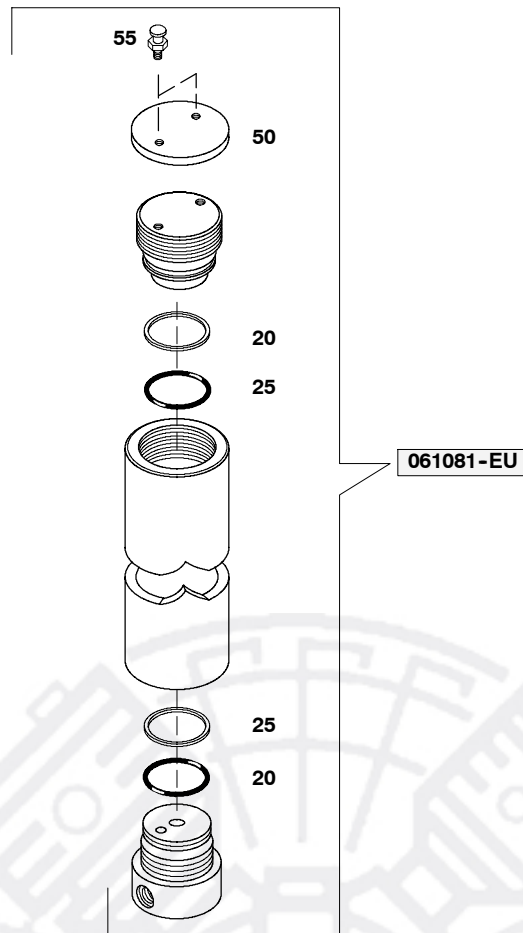
Wartungssätze
Mainenance kits
Kits d'entretien
Baugruppe 061081-EU Standard Filterbehälter PN 350
Assembly 061081-EU Standard Filter housing PN 350
Assemblage 061081-EU Filtre standard PN 350

G4.6- 7a

Klasse/ Class/ Classe			Pos.	Bestell-Nr. Part No. No. de cde.	Anz. Qty. Qté.	Benennung	Designation	Dénomination
a	b	c						
X			20	N4736	2	Stützring	back-up ring	bague d'appui
X			25	N4735	2	O-Ring	o-ring	joint torique
			30	78528	1	Fabrikschild	Ident. plate	plaque d'identification
			35	N3334	1	Niete	semitubular rivet	rivet semi-tubulaire
			40	N3333	3	Blindniete	pop rivet	rivet aveugle
			45	91024	1	Klebeschild	sticker	auto-collant
			50	61237	1	Schutzdeckel	protective cover	couvercle protecteur
			55	12293	2	Schraube	screw	vis

Filterpatronen / Filter cartridges / Cartouches de filtre

Bestell-Nr. Part No. No. de cde.	H ₂ O	Oil Huile	CO		Patronenfüllung ^{a)} Cartridge contents ^{a)} Matière filtrante ^{a)}
			CO	CO	
063282			●		HP

a) AC = Aktivkohle, MS = Molekularsieb, HP = Hopcalite, SEC = Securus
 AC = Activated charcoal, MS = Molecular sieve, HP = Hopcalite, SEC = Securus
 AC = Charbon actif, MS = Tamis moléculaire, HP = Hopcalite, SEC = Securus

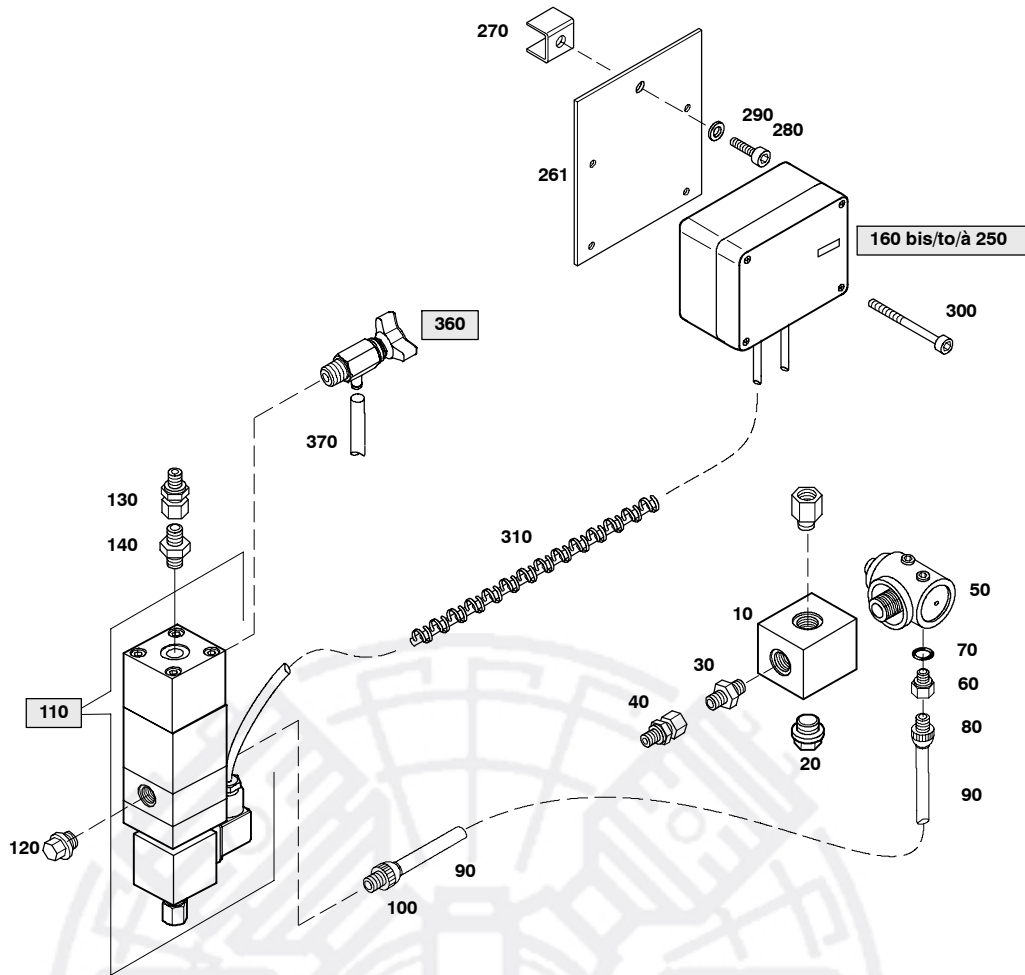

Ersatzteilsätze
Spare parts sets
Kits de pièces dét.

Baugruppe 078385
Assembly 078385
Assemblage 078385

Kondensat-Ablaufautomatik kpl.
Automatic condensate drain unit assy.
Purge automatique des condensats cpl.

G4.6- 8

Klasse/ Class/ Classe			Pos.	Bestell-Nr. Part No. No. de cde.	Anz. Qty. Qté.	Benennung	Designation	Dénomination
a	b	c						
			10	60887	1	Anschlußleiste	connecting block	bloc de raccordement
			20	N16266	1	Verschlußschraube	screw plug	bouchon fileté
			30	N20280	1	G-Einschraubstutzen	coupling	raccord
			40	N15922	1	G-Einschraubstutzen	coupling	raccord
			50	N90068	1	Druckminderer	pressure reducer	détendeur
			60	90174	1	Doppelnippel	coupling	raccord
			70	N3355	1	O-Ring	o-ring	joint torique
			80	N16332	1	Verschraubung	screw plug	bouchon fileté
			90	N90009	mm	Schlauch	hose	tuyau
			100	N16332	1	Verschraubung	screw plug	bouchon fileté
			110	060412	1	Kondensatventil	condensate drain valve	soupape de purge des condensats
			120	N16504	1	Verschlußschraube	screw plug	bouchon fileté
			130	N15600	1	G-Einschraubstutzen	coupling	raccord
			140	N20287	1	G-Einschraubstutzen	coupling	raccord
			150	N20017	1	G-Einschraubstutzen	coupling	raccord
			160	078355-V001	1	Steuerung 230VAC	control unit 230VAC	commande 230VAC
			170	078355-V002	1	Steuerung 115VAC	control unit 115VAC	commande 115VAC
			180	078355-V003	1	Steuerung 24VAC	control unit 24VAC	commande 24VAC
			190	078355-V004	1	Steuerung 24VDC	control unit 24VDC	commande 24VDC
			200	078355-V005	1	Steuerung 12VDC	control unit 12VDC	commande 12VDC
			210	078355-V006	1	Steuerung 230VAC;SEC-M	control unit 230VAC;SEC-M	commande 230VAC;SEC-M
			220	078355-V007	1	Steuerung 24VDC;SEC-M	control unit 24VDC;SEC-M	commande 24VDC;SEC-M
			230	078355-V008	1	Steuerung 115VAC;SEC-M	control unit 115VAC;SEC-M	commande 115VAC;SEC-M
			240	078355-V009	1	Steuerung 24VAC;SEC-M	control unit 24VAC;SEC-M	commande 24VAC;SEC-M
			250	078355-V010	1	Steuerung 12VDC;SEC-M	control unit 12VDC;SEC-M	commande 12VDC;SEC-M
			261	77886	1	Halterung	bracket	fixation
			270	090719	1	Befestigung	fitting	fixation
			280	N19552	1	Zylinderschraube	allen screw	vis allen
			290	N58	1	Scheibe	washer	DIN EN ISO 7090;B 8.4;St;A3A
			300	N27835	1	Kabelkanal	cable canal	canal pour câbles

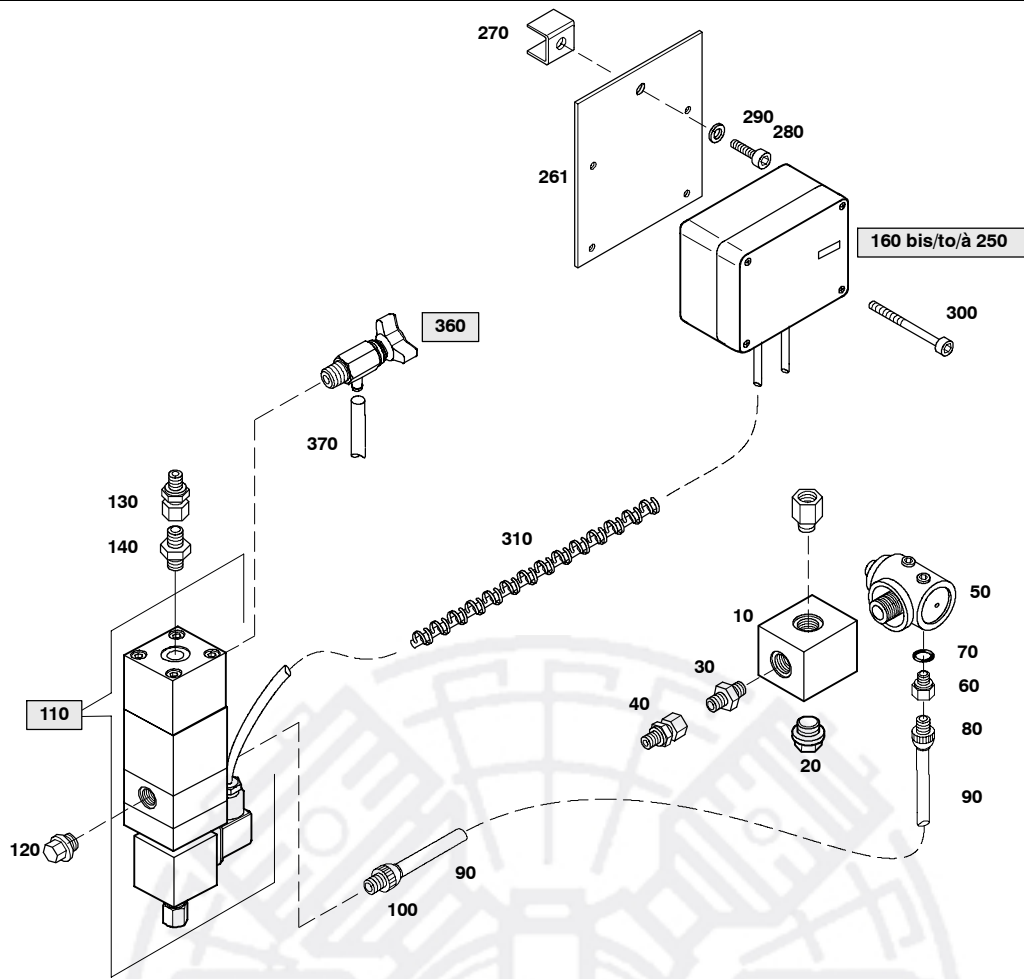

Ersatzteilsätze
Spare parts sets
Kits de pièces dét.

Baugruppe 078385
Assembly 078385
Assemblage 078385

Kondensat-Ablaufautomatik kpl.
Automatic condensate drain unit assy.
Purge automatique des condensats cpl.

G4.6- 8

Klasse/ Class/ Classe			Pos .	Bestell-Nr. Part No. No. de cde.	Anz. Qty. Qté.	Benennung	Designation	Dénomination
a	b	c						
			310	N27835-S01	1	Spreizniet	rivet	rivet
			360	011430	1	Ablabahn	drain tape	robinet de purge
			370	N25392	mm	Schlauch	hose	tuyau

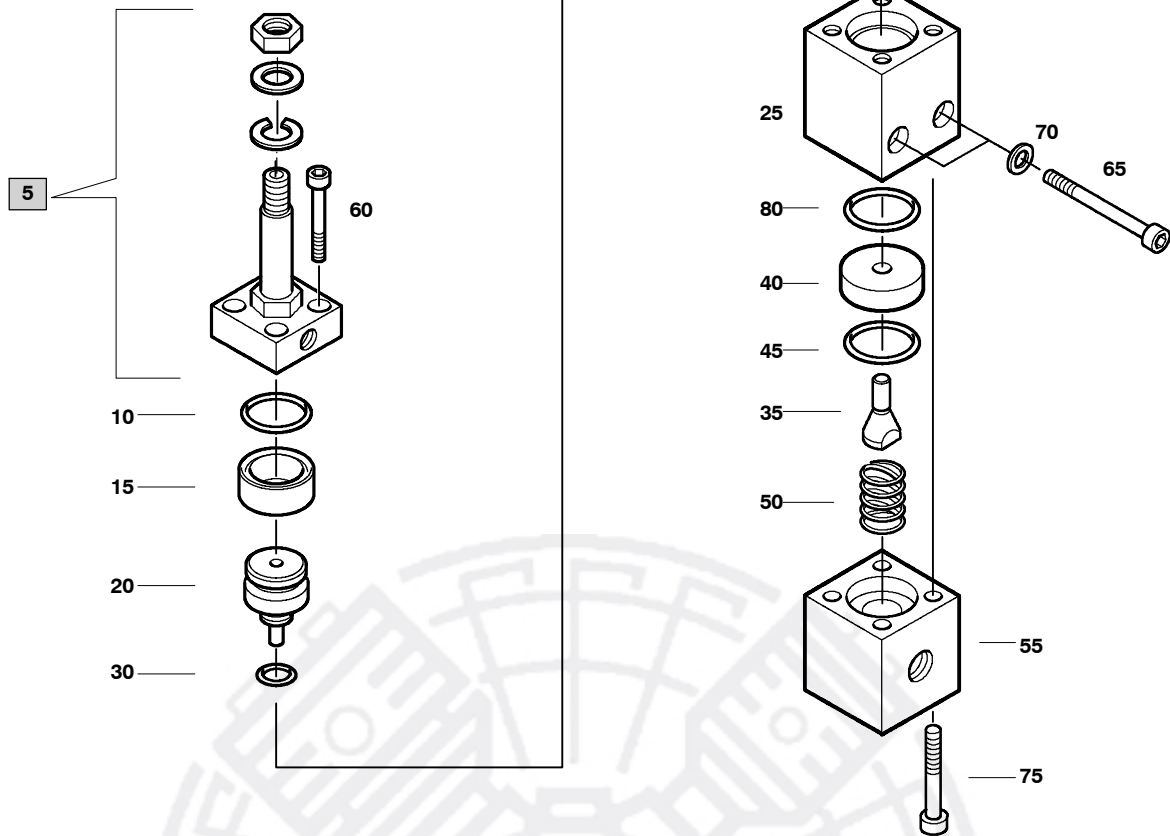

Ersatzteilsätze
 Spare parts sets
 Kits de pièces dét.

Baugruppe 060412 **Kondensat-Ablabventil**
Assembly 060412 **Condensate drain valve**
Assemblage 060412 **Soupage de purge des condensats**

G4.6- 8a

Klasse/ Class/ Classe			Pos.	Bestell-Nr. Part No. No. de cde.	Anz. Qty. Qté.	Benennung	Designation	Dénomination
a	b	c						
			5	058053	1	3/2-Wege-Magnetventil	3/2-way solenoid valve	électrovanne 3/2 voies
			10	N2720	1	O-Ring	o-ring	joint torique
			15	N4177	1	Nutring	grooved ring	anneau à gorge
			20	60417	1	Ventilkolben	valve piston	piston de soupape
			25	60414	1	Ventilkörper	valve housing	corps de soupape
			30	N3489	1	O-Ring	o-ring	joint torique
			35	60418	1	Dichtkegel	sealing cone	cône d'étanchéité
			40	60419	1	Ventilsitz	valve seat	siège de soupape
			45	N4178	1	O-Ring	o-ring	joint torique
			50	60600	1	Druckfeder	pressure spring	ressort de pression
			55	60415	1	Zwischen-Teil	intermediate part	pièce intermédiaire
			60	N19534	4	Zylinderschraube	cylinder screw	vis cylindrique
			65	N102	2	Scheibe, rund	washer	rondelle
			70	N19541	2	Zylinderschraube	cylinder screw	vis cylindrique
			75	N19539	4	Zylinderschraube	cylinder screw	vis cylindrique
			80	N2507	1	O-Ring	o-ring	joint torique

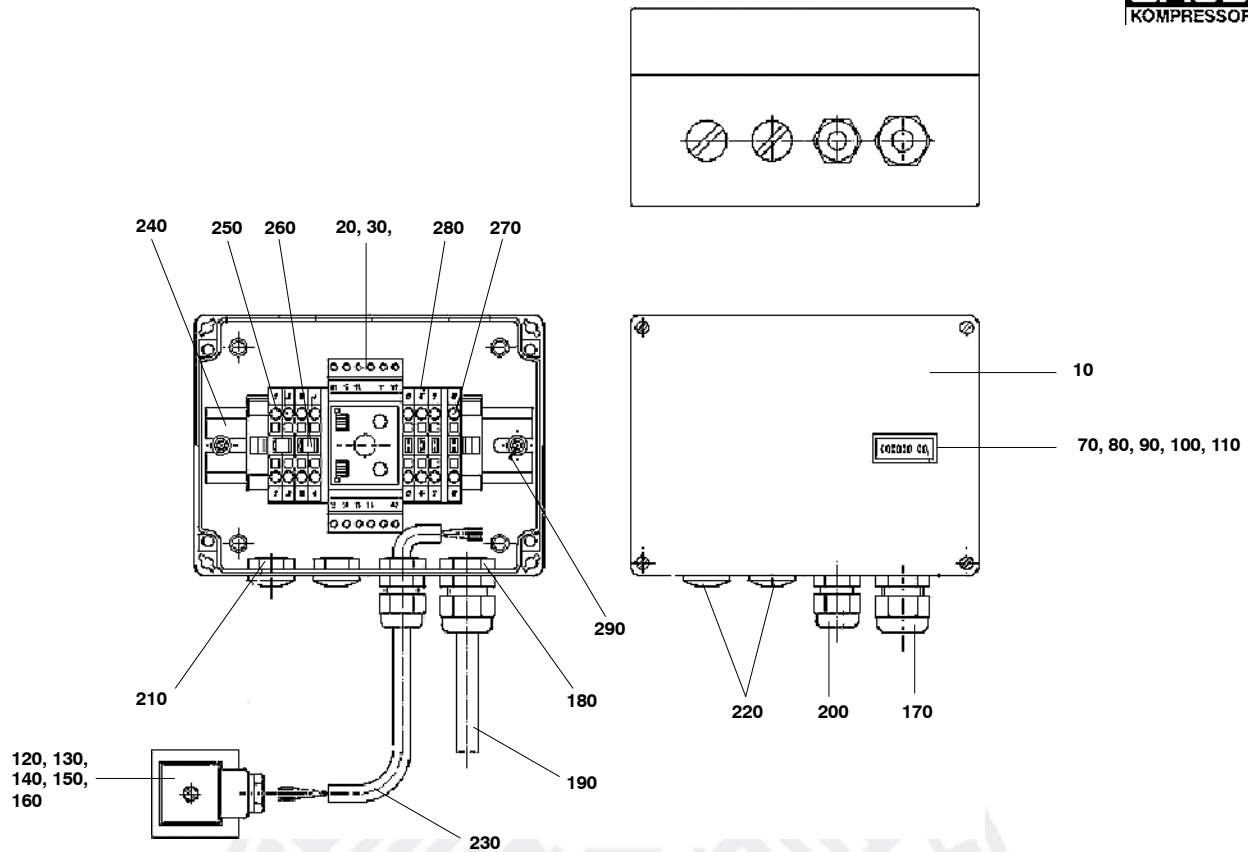

Ersatzteilsätze
 Spare parts sets
 Kits de pièces dét.

Baugruppe 078355 Steuerung
 Assembly 078355 Control unit
 Assemblage 078355 Commande

G4.6- 8b

Klasse/ Class/ Classe	Pos	Bestell-Nr. Part No. No. de cde.	Anz Qty. Qté.	Benennung	Designation	Dénomination
	10	78356	1	Gehäuse	housing	boîtier
	20	N16202	1	Taktgeber 220-230V/24VAC/DC	timing generator 220-230V/24VAC/DC	minuterie 220-230V/24VAC/DC
	30	N18781	1	Taktgeber 12-240VDC/24-240VAC	timing generator 12-240VDC/24-240VAC	minuterie 12-240VDC/24-240VAC
	70	N90050	1	Summierzähler 220VAC	cycles counter 220VAC	compteur de cycles 220VAC
	80	N90106	1	Summierzähler 110VAC	cycles counter 110VAC	compteur de cycles 110VAC
	90	N90052	1	Summierzähler 24VAC	cycles counter 24VAC	compteur de cycles 24VAC
	100	N90051	1	Summierzähler 24 VDC	cycles counter 24 VDC	compteur de cycles 24 VDC
	110	N20665	1	Summierzähler 12 VDC	cycles counter 12 VDC	compteur de cycles 12 VDC
	120	N4180	1	Magnetspule 230V	coil for solenoid valve 230V	bobine magnétique 230V
	130	N4182	1	Magnetspule 115V	coil for solenoid valve 115V	bobine magnétique 115V
	140	N18363	1	Magnetspule 24VAC	coil for solenoid valve 24VAC	bobine magnétique 24VAC
	150	N16099	1	Magnetspule 24 VDC	coil for solenoid valve 24 VDC	bobine magnétique 24VDC
	160	N4185	1	Magnetspule 12 VDC	coil for solenoid valve 12 VDC	bobine magnétique 12VDC
	170	N90161	1	Verschraubung	coupling	raccord
	180	N3104	1	Gegenmutter	counter nut	contre-écrou
	190	N90100	1	Netzanschlußkabel	cable	câble
	200	N90155	1	Verschraubung	coupling	raccord
	210	N21721	3	Gegenmutter	counter nut	contre-écrou
	220	N20654	2	Verschlußschraube	screw plug	bouchon fileté
	230	N21665	1.8	Steuerleitung	cab cable	câble d'alimentation
	240	N17276	145	Tragschiene	support rail	rail de fixation
	250	N22063	7	Durchgangsklemme	built-up connection	borne de phase
	260	N22505	2	Querverbindung	lateral connection	connexion transversale
	270	N22064	1	Schutzleiterklemme	grounded connection	borne de terre
	280	N22522	7	Schild	label	étiquette
	290	N22108	1	Ringkabelschuh	cable terminal	cosse

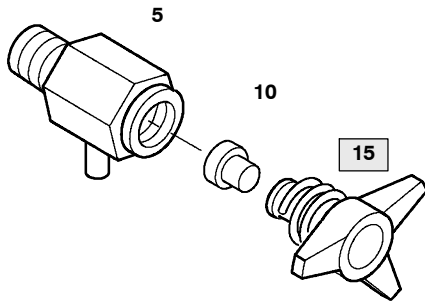
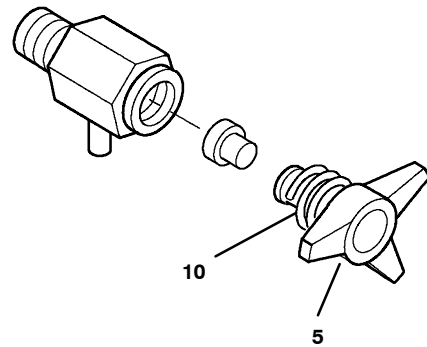
G4.6- 8c

G4.6- 8d

 Ersatzteilsätze
 Spare parts sets
 Kits de pièces dét.

Baugruppe 011430 **Ablaßhahn**
Assembly 011430 **Drain tap**
Assemblage 011430 **Robinet de purge**
G4.6- 8c

Klasse/ Class/ Classe			Pos.	Bestell-Nr. Part No. No. de cde.	Anz. Qty. Qté.	Benennung	Designation	Dénomination
a	b	c						
			5	068410	1	Ablaßhahnkörper, kpl.	drain valve housing	corps de robinet de purge
X			10	13283	1	Dichtung	gasket	joint
			15	055888	1	Knebelschraube m. Feder	tommy screw with spring	molette avec ressort

 Wartungssätze
 Maintenance sets
 Kits de maintenance

Baugruppe 055888 **Knebelschraube mit Sicherungsfeder**
Assembly 055888 **Tommy screw with retaining spring**
Assemblage 055888 **Molette avec ressort**
G4.6- 8d

Klasse/ Class/ Classe			Pos.	Bestell-Nr. Part No. No. de cde.	Anz. Qty. Qté.	Benennung	Designation	Dénomination
a	b	c						
			5	11392	1	Knebelschraube	tommy screw	molette
			10	13284	1	Sicherungsfeder	locking spring	ressort d'arrêt

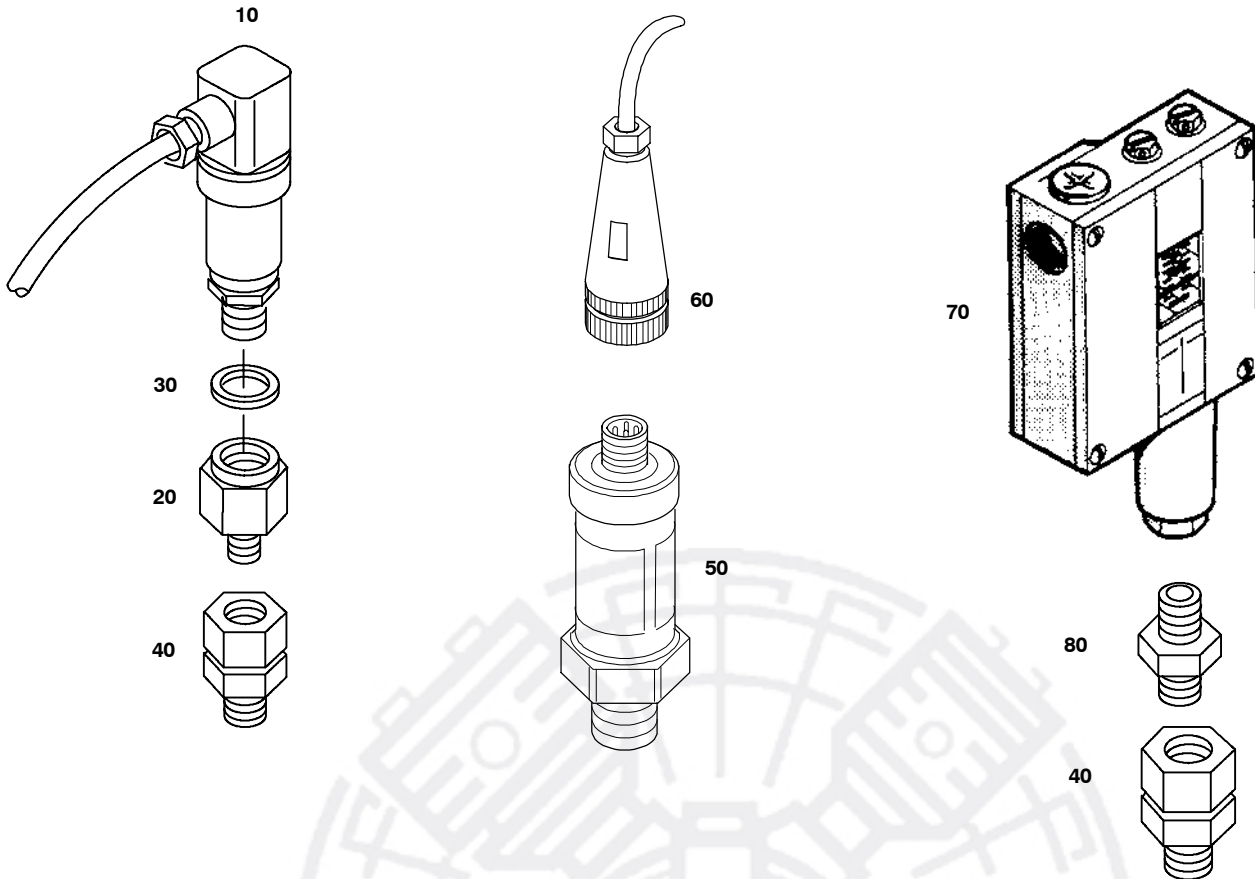

Wartungssätze
 Maintenance kits
 Kits d'entretien

Baugruppe 80881
 Assembly 80881
 Assemblage 80881

Drucküberwachung kpl.
 Pressure control assy.
 Surveillance de la pression cpl.

G4.6- 9

Klasse/ Class/ Classe			Pos.	Bestell-Nr. Part No. No. de cde.	Anz. Qty. Qté.	Benennung	Designation	Dénomination
a	b	c						
			10	N19999	1	Druckmeßumformer	pressure switch	pressostat
			20	N20493	1	Manometer-Aufschraubstutzen	manometer coupling	raccord pour manomètre
			30	N3081	1	Dichtkantring	gasket	joint
			40	N15600	1	G-Einschraubstutzen	coupling	raccord
			50	N25421	1	Druckmeßumformer	pressure switch	pressostat
			60	N25785	1	Verlängerungskabel	cable	rallonge
			70	N4526	1	Druckschalter	pressure switch	pressostat
			80	N20287	1	G-Einschraubstutzen	coupling	raccord

