

Ersatzteilliste
Spare parts catalogue
Liste des pièces

G24.1 Filtersystem P100-420D
G24.1 Filter system P100-420D
G24.1 Systèmes de filtration P100-420D



Baugruppe	Assembly	Assemblage	Bild/Fig.
Rahmen	Frame	Cadre	G24.1- 1
Öl- und Wasserabscheider	Oil and water separator	Séparateur d'huile et d'eau	G24.1- 2
Feinnachreiniger	Purifier	Epurateur	G24.1- 3

HINWEIS

Diese Ersatzteilliste ist für unterschiedliche Konfigurationen gültig; Der tatsächliche Lieferumfang kann insbesondere bei den Anbau- und Zubehörteilen von den dargestellten Baugruppen und Teilen abweichen.

NOTE

This parts list covers different configurations; the delivery scope, especially for the mounting and accessory parts may differ from the assemblies and parts shown.

NOTE

Cette liste de pièces est valable pour des configurations diverses; il est donc possible que les pièces et les assemblages livrés soient différents des pièces et assemblages indiqués, en particulier les éléments de montage et les accessoires.

Änder.-Nr. Change no. No. de change	Datum Date	Änderung	Change	Changement
0	01.06.96	Grundausgabe	Basic edition	Edition de base
1	01.10.98	Wartungssätze	Maintenance kits	Kits d'entretien

Wichtige Hinweise für Teilebestellung:

Bestell-Nr., die mit der Ziffer 0 beginnen, bezeichnen Baugruppen, die komplett geliefert werden. Teile ohne Bestell-Nr. sind nur zur Information für die Montage aufgeführt. Sie sind nicht als Ersatzteil erhältlich. Bei Ersatzteilbestellungen erwarten Sie unsere richtige Lieferung; deshalb benötigen wir von Ihnen folgende Angaben (siehe unten gezeigtes Typenschild):

1. Modellbezeichnung, Fabrik-Nr. sowie Fertigungsstand von Anlage/Block
2. Stückzahlen
3. Benennung und Best.-Nr. des gewünschten Teils

Bestell-Beispiel:

Für Kompressorblock ...
Fabrik-Nr. 524-0528/1/2 drei Dichtungen
8263-090

Important notes for spare parts orders:

Part nos. beginning with digit 0 indicate parts available as complete assemblies. Parts without part no. are indicated for assembly reference, only. These parts are not available as single parts. When placing an order for spare parts, please give the following items so as to ensure our correct delivery (see identification plate shown below):

1. Model, serial no. as well as design standard of unit/block
2. Quantity required
3. Name and part no.

Example for order:

For compressor block ...
serial no. 524-0528/1/2, three gaskets
8263-090

Avis important pour la commande de pièces:

Les nos. de commande commençant par le chiffre 0 indiquent les pièces livrées au complet. Les pièces sans no. de commande sont indiquées uniquement pour information de montage. Elles ne sont pas livrées individuellement. Pour que la livraison de pièces de rechange corresponde à la commande, veuillez bien nous fournir les données suivantes (voir plaque d'identité ci-dessous):

1. Modèle, no. de série et standard de construction de bloc compresseur/groupe
2. Quantité désirée
3. Dénomination et no. de commande de la pièce désirée

Exemple de commande:

Pour bloc compresseur ...
no. de série 524-0528/1/2, trois joints no. de cde. 8263-090



Wartungssätze

- a =Wartungssatz 1000 h
- b =Wartungssatz 2000 h
- c =Wartungssatz 4000 h



Maintenance kit

- a = Maintenance kit 1000 h
- b = Maintenance kit 2000 h
- c = Maintenance kit 4000 h



Kits de pièces d'entretien :

- a = Kit d'entretien 1000 h
- b = Kit d'entretien 2000 h
- c = Kit d'entretien 4000 h

In den Spalten sind die im entsprechenden Satz enthaltenen Teile angekreuzt. Bitte beachten, daß die höheren Sätze die untergeordneten nicht beinhalten, d.h. für eine 4000-Stunden-Wartung wird 1x Satz a, 1x Satz b und 1x Satz c benötigt.

The columns contain the parts that are included in the respective parts set. Please note that the higher graded kits do not include the lower ones, i.e. for a 4000 hours maintenance, one kit a, one kit b plus one kit c are required.

Les pièces contenues dans les kits correspondants sont marquées d'une croix dans les colonnes. Veuillez observer que les kits supérieurs ne contiennent pas les kits subordonnés, c'est-à-dire pour un entretien de 4000 heures il faut avoir 1x kit a, 1x kit b et 1x kit c.

**Anmerkungen zur Identifikation:
Remarks for identification:
Remarques pour l'identification:**

Modell/Model/Modèle		Fabrik-Nr./Serial no./Numéro de série	
<input type="checkbox"/>		<input type="checkbox"/>	
Volumenstrom m ³ /min	<input type="checkbox"/>	Jahr/Year	<input type="checkbox"/>
Free air delivery Scfm	<input type="checkbox"/>	n/min. r.p.m.	<input type="checkbox"/>
Betriebsüberdruck bar	<input type="checkbox"/>	kW	<input type="checkbox"/>
Max. working press. psig	<input type="checkbox"/>	CE	<input type="checkbox"/>
		KB 73708	Fertigungsstand / Modification no. / No. de modification
			Anlage/Unit/Groupe
			Kompressorblock/ Compressor block/ Bloc compresseur



ACHTUNG

Nur Schrauben und Stiftschrauben der Qualität 8.8 verwenden!



ATTENTION

Use only screws and studs in quality 8.8! This quality is equivalent to SAE J 429 grade 5.



ATTENTION

N'utiliser que des vis et des goujons filetés de la qualité 8.8!

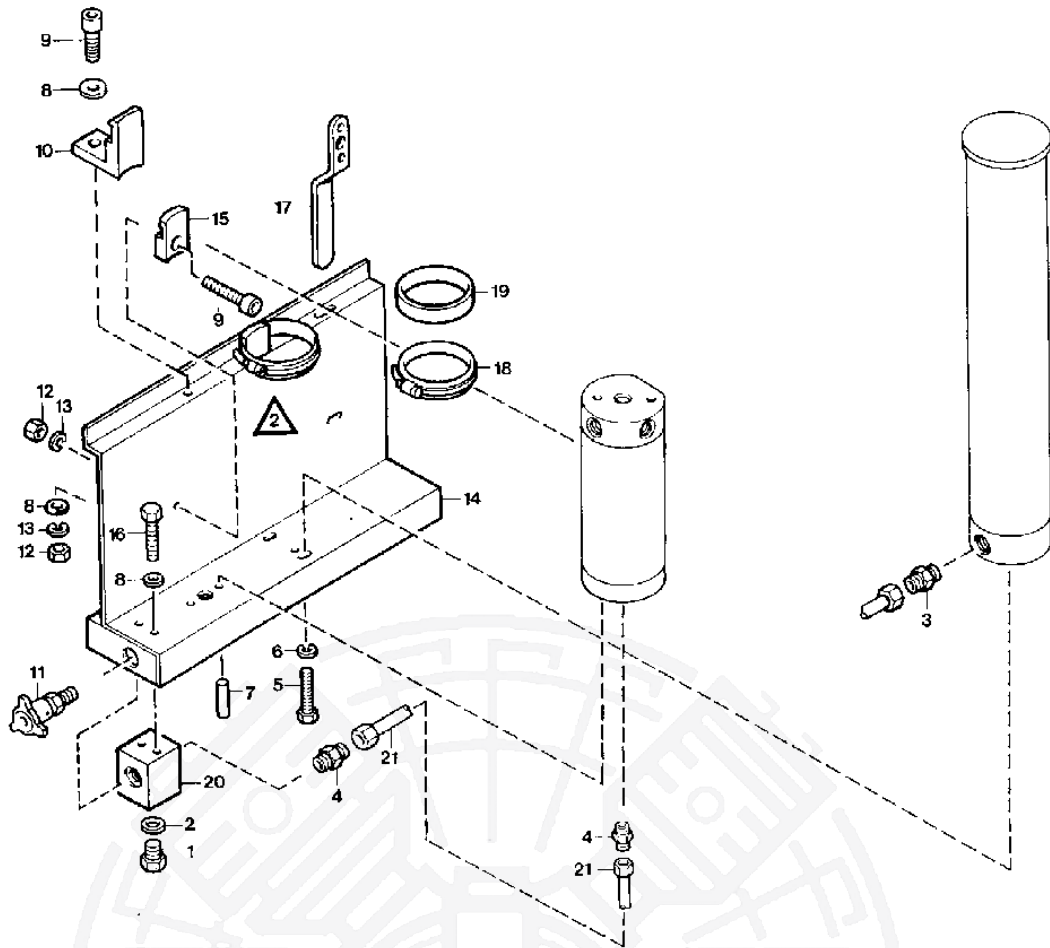
Wartungssätze
Mainenance kits
Kits d'entretien
Baugruppe 077505
Assemlly 077505
Assemblage 077505

Rahmen
Frame
Cadre

G24.1- 1

Klasse/ Class/ Classe			Pos.	Bestell-Nr. Part No. No. de cde.	Anz. Qty. Qté.	Benennung	Designation	Dénomination
a	b	c						
			1	N52		Verschlußschraube	Plug	Bouchon fileté
			2	N1316		Dichtung	Gasket	Joint
			3	N16265		Gerade Rohrverschraubung	Male connector	Raccord droit mâle
			4	N3816		Gerade Rohrverschraubung	Male connector	Raccord droit mâle
			5	N570		Sechskantschraube	Hex. bolt	Vis hex.
			6	N16		Scheibe	Washer	Rondelle
			7	N3297		Zylinderkerbstift	Stud	Goupille
			8	N102		Scheibe	Washer	Rondelle
			9	N210		Innensechskantschraube	Allen screw	Vis à six pans creux
			10	61646		Filterhalter	Filter bracket	Fixation de séparateur
			11	011430		Kondensatablaßhahn	Condensate drain valve	Robinet de purge
			12	N287		Sechskantmutter	Hex. nut	Ecrou hex.
			13	N100		Federscheibe	Lock washer	Rondelle élastique
			14	67232		Filterkonsole	Console	Console
			15	64570		Filterhalter	Filter bracket	Fixation de séparateur
			16	N53		Sechskantschraube	Hex. bolt	Vis hex.
			17	60074		Schlüssel	Wrench	Clé
			18	N15499		Schneckenwindeschelle	Clamp	Collier
			19	N15500		Gummiprofil	Rubber band	Profilé en caoutchouc
			20	62571		Aufnahmevierkant	Block	Moyeu flasque
			21	N3616*		Verbindungsleitung	Connecting tube	Conduite de connexion

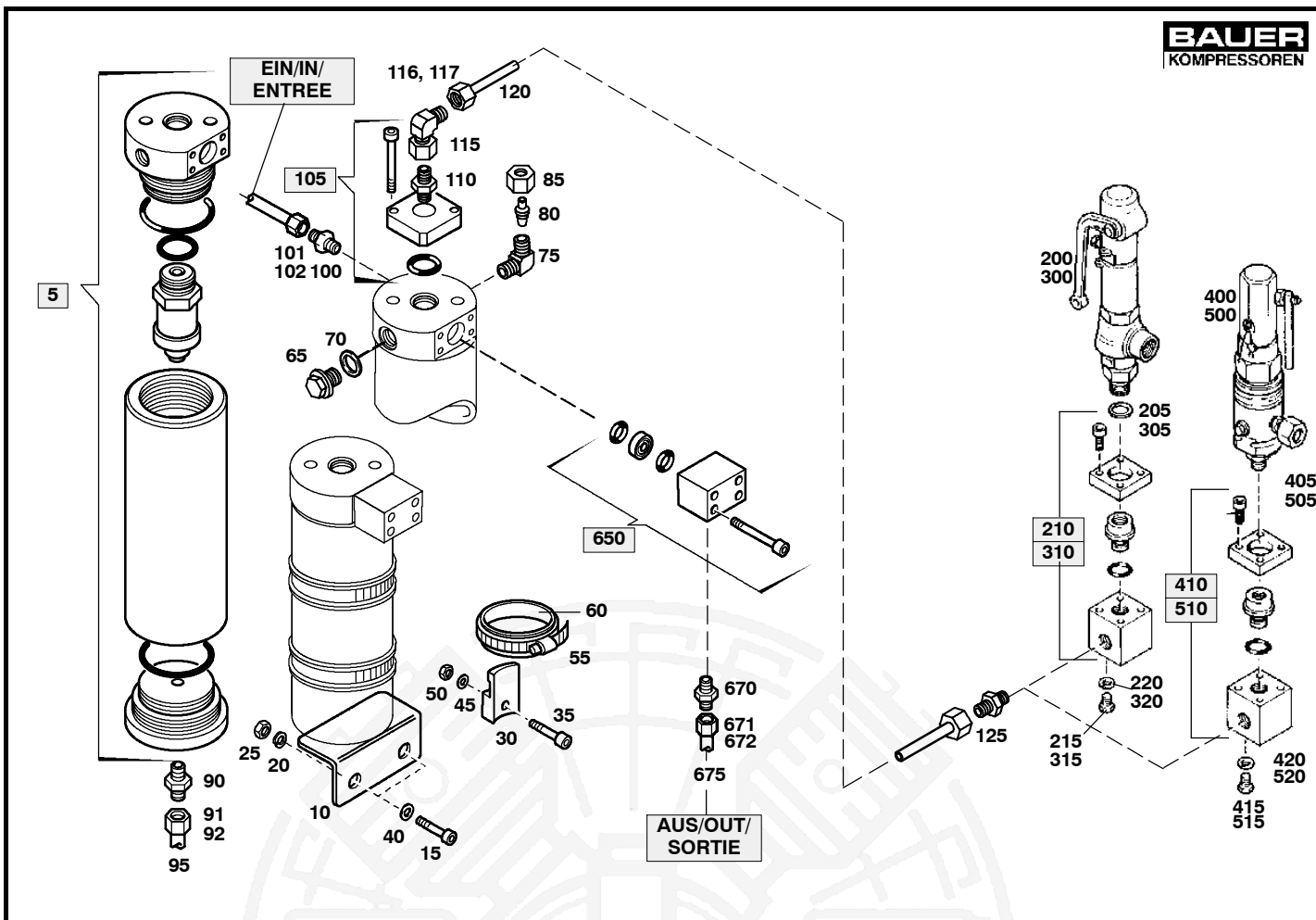

Wartungssätze
 Maintenance kits
 Kits d'entretien

Baugruppe 075203
 Assembly 075203
 Assemblage 075203

Öl- und Wasserabscheider
 Oil and water separator
 Séparateur d'huile et d'eau

G24.1- 2

Klasse/ Class/ Classe			Pos.	Bestell-Nr. Part No. No. de cde.	Anz. Qty. Qté.	Benennung	Designation	Dénomination
a	b	c						
			120	N3619*	mm	Nahtloses Rohr	stainless steel tube 8x1.5	tuyau en acier inox 8x1.5
			125	N20404	1	Gerader-Einschraubst.	Screwed socket	raccord droit mâle
			126	N3608	1	Überwurfmutter	screw cap	écrou borgne
			127	N3609	1	Schneidring	cutting ring	bague coupante
			200	N17162	1	Sicherheitsventil	safety valve	soupape de sûreté
			205	N4261	1	Dichtring	gasket	joint
			210	067799	1	Aufnahme kpl.	mounting piece	adaptateur
			215	N19503	2	Sechskantschraube	hexagon nut	vis
			220	N108	2	Federring	spring washer	rondelle-ressort
			225	N52	1	Verschlußschraube	plug	bouchon fileté
			230	N4602	1	USIT-Ring	usit-ring	joint usit
			235	N7829	1	Gewinde-Reduzierst.	reducing coupling	raccord réducteur
			240	N8114	1	Dichtring	gasket	joint
			245	N20280	1	Gerader-Einschraubst.	straight screwed socket	raccord droit mâle
			246	N15599	1	Überwurfmutter	screw cap	écrou borgne
			247	N7441	1	Schneidring	cutting ring	bague coupante
			250	N16242*	mm	Nahtloses Rohr	stainless steel tube 12x2	tuyau en acier inox 12x2
			255	N20281	1	Winkel-Einschraubst.	elbow screwed socket	coude
			256	N15599	1	Überwurfmutter	screw cap	écrou borgne
			257	N7441	1	Schneidring	cutting ring	bague coupante
			260	N4204	1	Gewinde-Reduzierst.	reducing coupling	raccord réducteur
			265	N4261	1	Dichtring	gasket	joint
			300	N2315	1	Sicherheitsventil	safety valve	soupape de sûreté
			305	N4261	1	Dichtring	gasket	joint
			310	067799	1	Aufnahme kpl.	mounting piece	adaptateur
			315	N19503	2	Sechskantschraube	hexagon nut	vis
			320	N108	2	Federring	spring washer	rondelle-ressort
			325	N52	1	Verschlußschraube	plug	bouchon fileté
			330	N4602	1	USIT-Ring	usit-ring	joint usit

*

Meterware

Piece goods

Marchandise au mètre

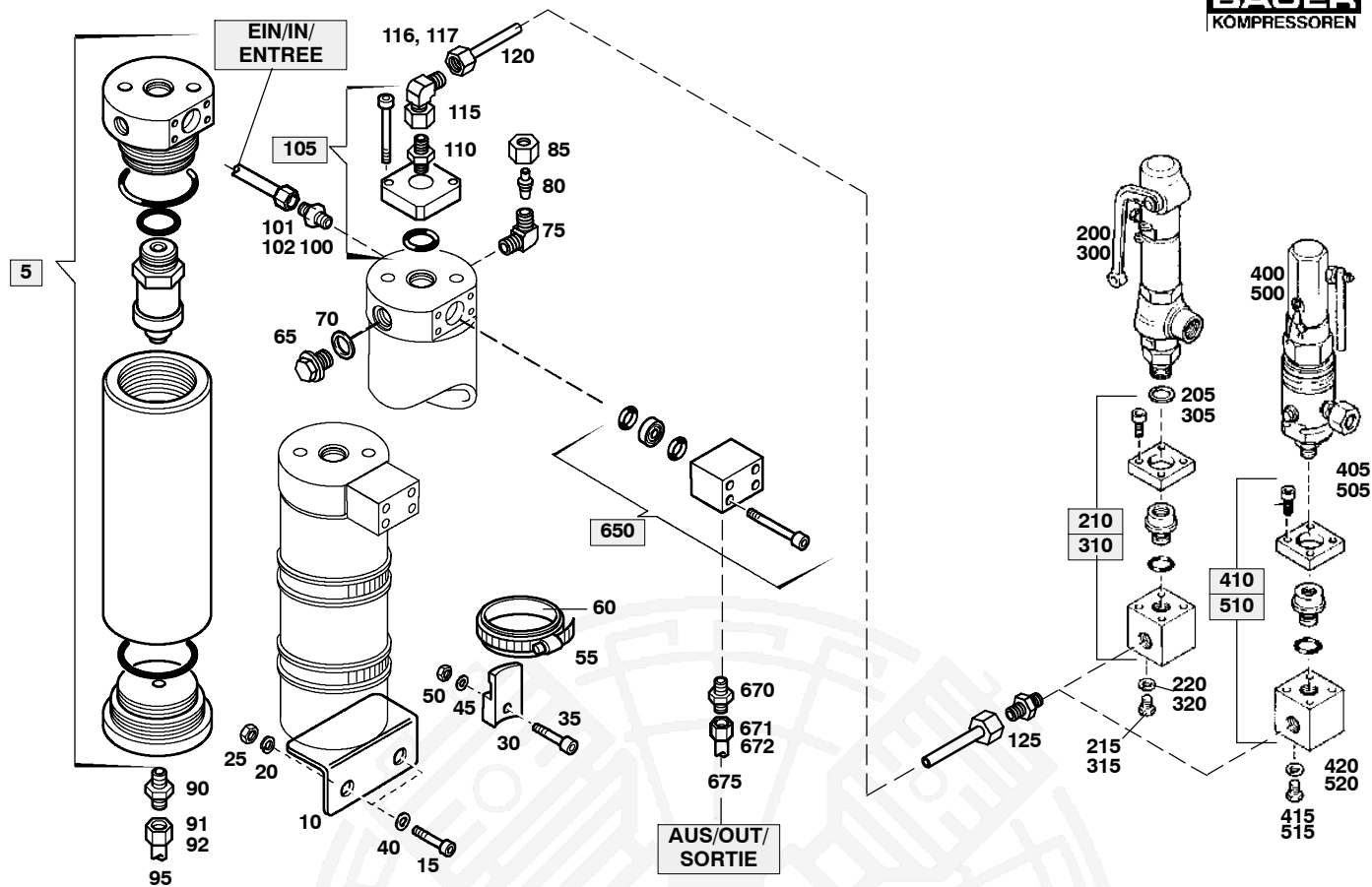

Wartungssätze
 Maintenance kits
 Kits d'entretien

Baugruppe 075203
 Assembly 075203
 Assemblage 075203

Öl- und Wasserabscheider
 Oil and water separator
 Séparateur d'huile et d'eau

G24.1- 2

Klasse/ Class/ Classe			Pos.	Bestell-Nr. Part No. No. de cde.	Anz. Qty. Qté.	Benennung	Designation	Dénomination
a	b	c						
			335	N7829	1	Gewinde-Reduzierst.	reducing coupling	raccord réducteur
			340	N8114	1	Dichtring	gasket	joint
			345	N20280	1	Gerader-Einschraubst.	straight screwed socket	raccord droit mâle
			346	N15599	1	Überwurfmutter	screw cap	écrou borgne
			347	N7441	1	Schneidring	cutting ring	bague coupante
			350	N16242*	mm	Nahtloses Rohr	stainless steel tube 12x2	tuyau en acier inox 12x2
			355	N20281	1	Winkel-Einschraubst.	elbow screwed socket	coude
			356	N15599	1	Überwurfmutter	screw cap	écrou borgne
			357	N7441	1	Schneidring	cutting ring	bague coupante
			360	N4204	1	Gewinde-Reduzierst.	reducing coupling	raccord réducteur
			365	N4261	1	Dichtring	gasket	joint
			400	N17066	1	Sicherheitsventil	safety valve	soupape de sûreté
			405	N293	1	Dichtring	gasket	joint
			410	067800	1	Aufnahme kpl.	mounting piece	adaptateur
			415	N19503	2	Sechskantschraube	hexagon nut	vis
			420	N108	2	Federring	spring washer	rondelle-ressort
			425	N52	1	Verschlußschraub	plug	bouchon fileté
			430	N4602	1	USIT-Ring	usit-ring	joint usit
			435	N4228	1	Gewinde-Reduzierst.	reducing coupling	raccord réducteur
			440	N293	1	Dichtring	gasket	joint
			445	N20280	1	Gerader-Einschraubst.	straight screwed socket	raccord droit mâle
			446	N15599	1	Überwurfmutter	screw cap	écrou borgne
			447	N7441	1	Schneidring	cutting ring	bague coupante
			450	N16242	mm	Nahtloses Rohr	stainless steel tube 12x2	tuyau en acier inox 12x2
			455	N20281	1	Winkel-Einschraubst.	elbow screwed socket	coude
			456	N15599	1	Überwurfmutter	screw cap	écrou borgne
			457	N7441	1	Schneidring	cutting ring	bague coupante
			460	N4204	1	Gewinde-Reduzierst.	reducing coupling	raccord réducteur
			465	N4261	1	Dichtring	gasket	joint

*

Meterware

Piece goods

Marchandise au mètre

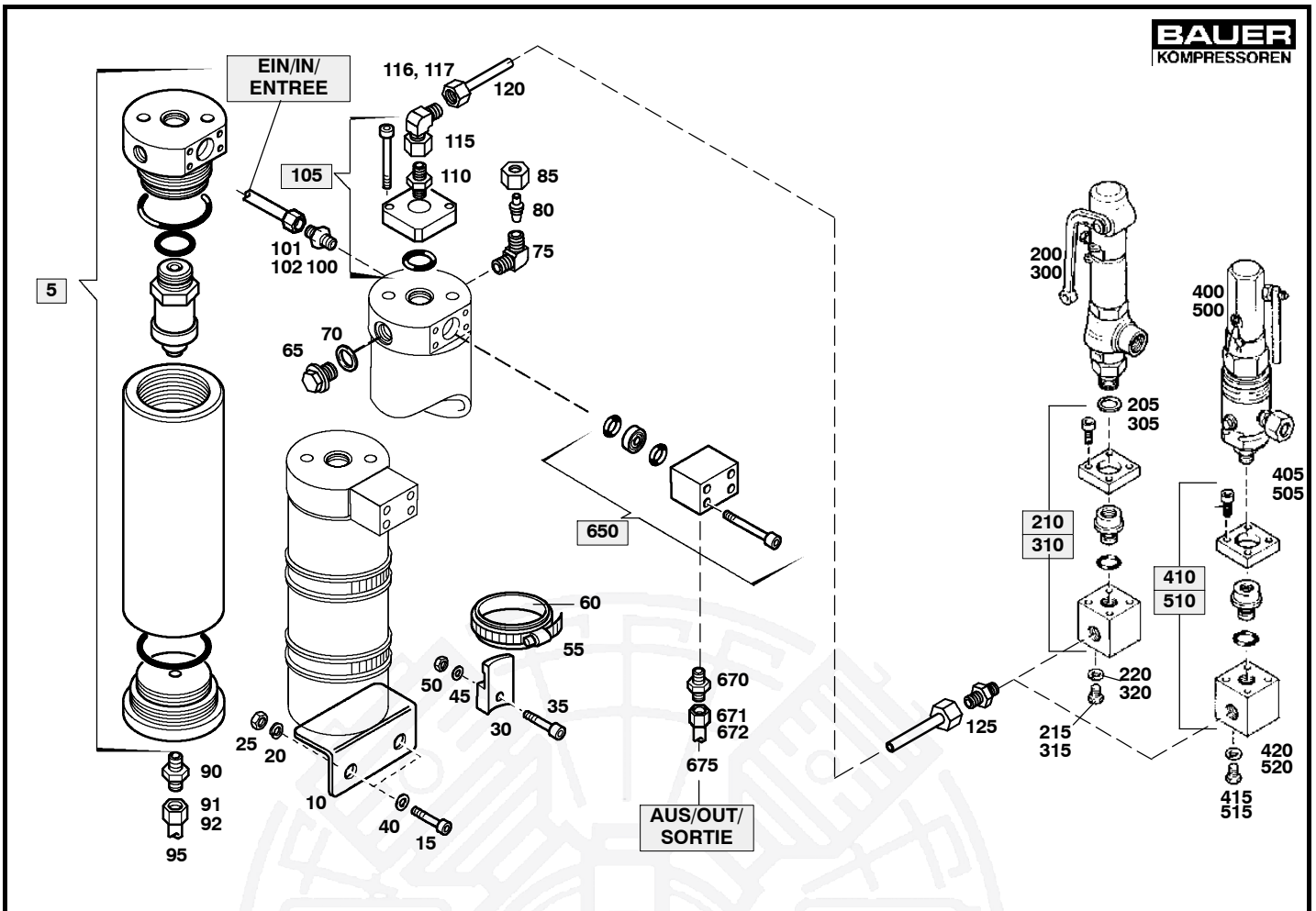

Wartungssätze
Maintenance kits
Kits d'entretien

Baugruppe 075203
Assembly 075203
Assemblage 075203

Öl- und Wasserabscheider
Oil and water separator
Séparateur d'huile et d'eau

G24.1- 2

Klasse/ Class/ Classe			Pos.	Bestell-Nr. Part No. No. de cde.	Anz. Qty. Qté.	Benennung	Designation	Dénomination
a	b	c						
			500	N16778	1	Sicherheitsventil	safety valve	soupe de sûreté
			505	N293	1	Dichtring	gasket	joint
			510	067800	1	Aufnahme kpl.	mounting piece	adaptateur
			515	N19503	2	Sechskantschraube	hexagon nut	vis
			520	N108	2	Federring	spring washer	rondelle-ressort
			525	N52	1	Verschlußschraube	plug	bouchon fileté
			530	N4602	1	USIT-Ring	usit-ring	joint usit
			535	N4228	1	Gewinde-Reduzierst	reducing coupling	raccord réducteur
			540	N293	1	Dichtring	gasket	joint
			545	N20280	1	Gerader-Einschraubst.	straight screwed socket	raccord droit mâle
			546	N15599	1	Überwurfmutter	screw cap	écrou borgne
			547	N7441	1	Schneidring	cutting ring	bague coupante
			550	N16242*	mm	Nahtloses Rohr	stainless steel tube 12x2	tuyau en acier inox 12x2
			555	N20281	1	Winkel-Einschraubst	elbow screwed socket	coude
			556	N15599	1	Überwurfmutter	screw cap	écrou borgne
			557	N7441	1	Schneidring	cutting ring	bague coupante
			560	N4204	1	Gewinde-Reduzierst.	reducing coupling	raccord réducteur
			565	N4261	1	Dichtring	gasket	joint
			610	N20287	1	Gerader-Einschraubst.	union	raccord droit mâle
			611	N3608	1	Überwurfmutter	screw cap	écrou borgne
			612	N3609	1	Schneidring	cutting ring	bague coupante
			650	090126	1	Abgangskörper kpl.	outlet cpl.	raccord de sortie
			670	N20287	1	Gerader-Einschraubst.	union	raccord droit mâle
			671	N3608	1	Überwurfmutter	screw cap	écrou borgne
			672	N3609	1	Schneidring	cutting ring	bague coupante
			675	N3619*	mm	Nahtloses Rohr	stainless steel tube 8x1.5	tuyau en acier inox 8x1.5
			680	N3202	2	Rohrclip	tube clamp	clip de tube
			685	N19533	2	Zylinderschraube	cylinder screw	vis cylindrique
			690	N102	2	Scheibe	washer	rondelle

*
*

Meterware
Meterware

Piece goods
Piece goods

Marchandise au mètre
Marchandise au mètre

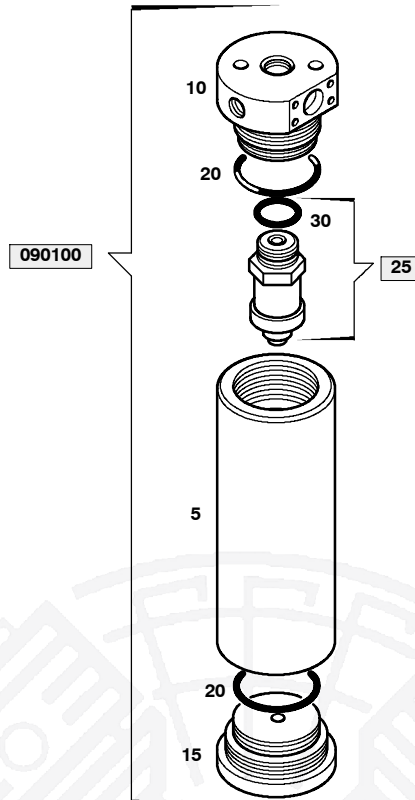

Wartungssätze
 Maintenance kits
 Kits d'entretien

Baugruppe 090100 Endabscheider
 Assembly 090100 Final separator
 Assemblage 090100 Séparateur final

G24.1- 2a

Klasse/ Class/ Classe			Pos.	Bestell-Nr. Part No. No. de cde.	Anz. Qty. Qté.	Benennung	Designation	Dénomination
a	b	c						
			5	*	1	Behältergehäuse	filter housing	corps de filtre
			10	*	1	Behälterdeckel	filter head	tête de filtre
			15	*	1	Behälterboden	filter bottom	fond de filtre
X			20	N4586	2	O-Ring	o-ring	joint torique
X			25	061860	1	Microfilterpatrone	filter cartridge	cartouche de filtre
			30	N4385	2	O-Ring	o-ring	joint torique

*

nur kpl. lieferbar

available as cpl. assy- only

ne sont livrées qu'ensemble

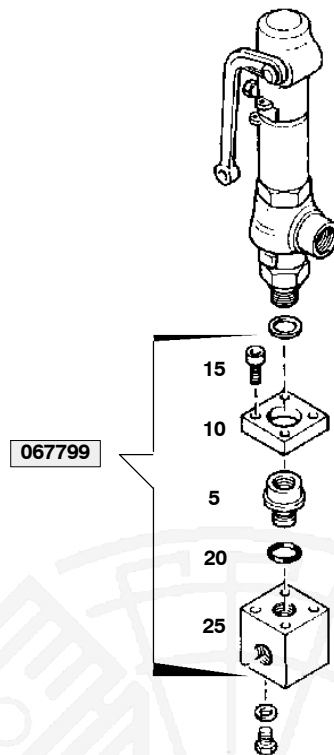

Wartungssätze
 Maintenance kits
 Kits d'entretien

Baugruppe 067799
 Assembly 067799
 Assemblage 067799

Aufnahme kpl.
 Adapter assy.
 Adaptateur cpl.

G24.1- 2b

Klasse/ Class/ Classe			Pos.	Bestell-Nr. Part No. No. de cde.	Anz. Qty. Qté.	Benennung	Designation	Dénomination
a	b	c						
			5	64118	1	Aufnahme	adapter	adaptateur
			10	64119	1	Flansch	flange	bride
			15	N61	4	Zylinderschraube	allen screw	vis à six pans creux
			20	N4882	1	O-Ring	o-ring	joint torique
			25	67798	1	Aufnahme	bracket	connecteur

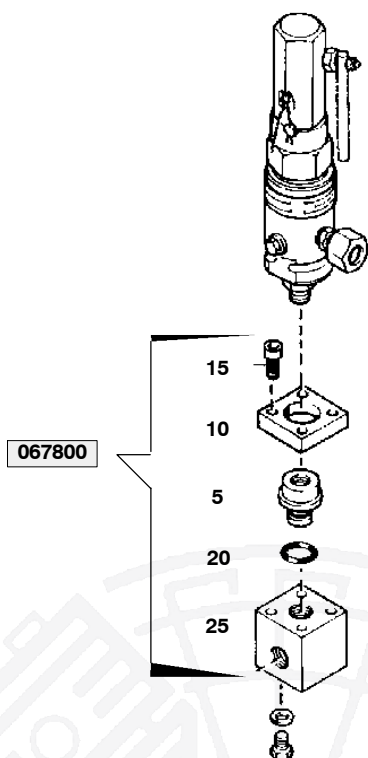

Wartungssätze
 Maintenance kits
 Kits d'entretien

Baugruppe 067800
 Assembly 067800
 Assemblage 067800

Aufnahme kpl.
 Adapter assy.
 Adaptateur cpl.

G24.1- 2c

Klasse/ Class/ Classe			Pos.	Bestell-Nr. Part No. No. de cde.	Anz. Qty. Qté.	Benennung	Designation	Dénomination
a	b	c						
			5	67797	1	Aufnahme	adapter	adaptateur
			10	64119	1	Flansch	flange	bride
			15	N19548	4	Zylinderschraube	allen screw	vis à six pans creux
			20	N4882	1	O-Ring	o-ring	joint torique
			25	68520	1	Aufnahme	bracket	connecteur

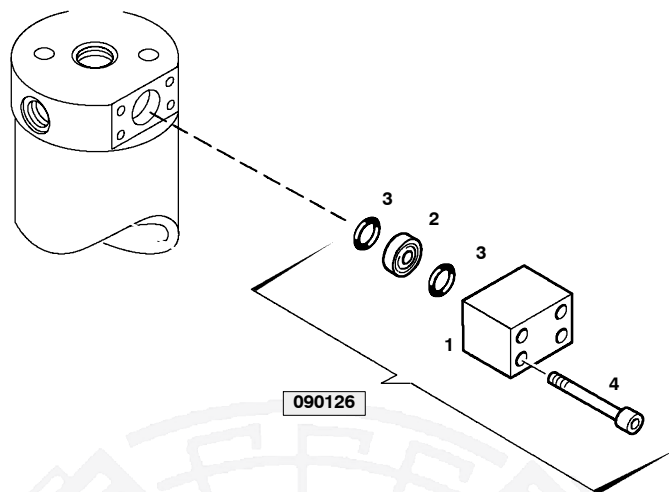

Wartungssätze
 Maintenance kits
 Kits d'entretien

Baugruppe 090126
 Assembly 090126
 Assemblage 090126

Adapter
 Adapter
 Adaptateur

G24.1- 2d

Klasse/ Class/ Classe			Pos.	Bestell-Nr. Part No. No. de cde.	Anz. Qty. Qté.	Benennung	Designation	Dénomination
a	b	c						
			1	90059	1	Abgangskörper	outlet	sortie
			2	63998	1	Scheibe	washer	rondelle
			3	N4178	2	O-Ring	o-ring	joint torique
			4	N724	4	Zylinderschraube	allen screw	vis à six pans creux

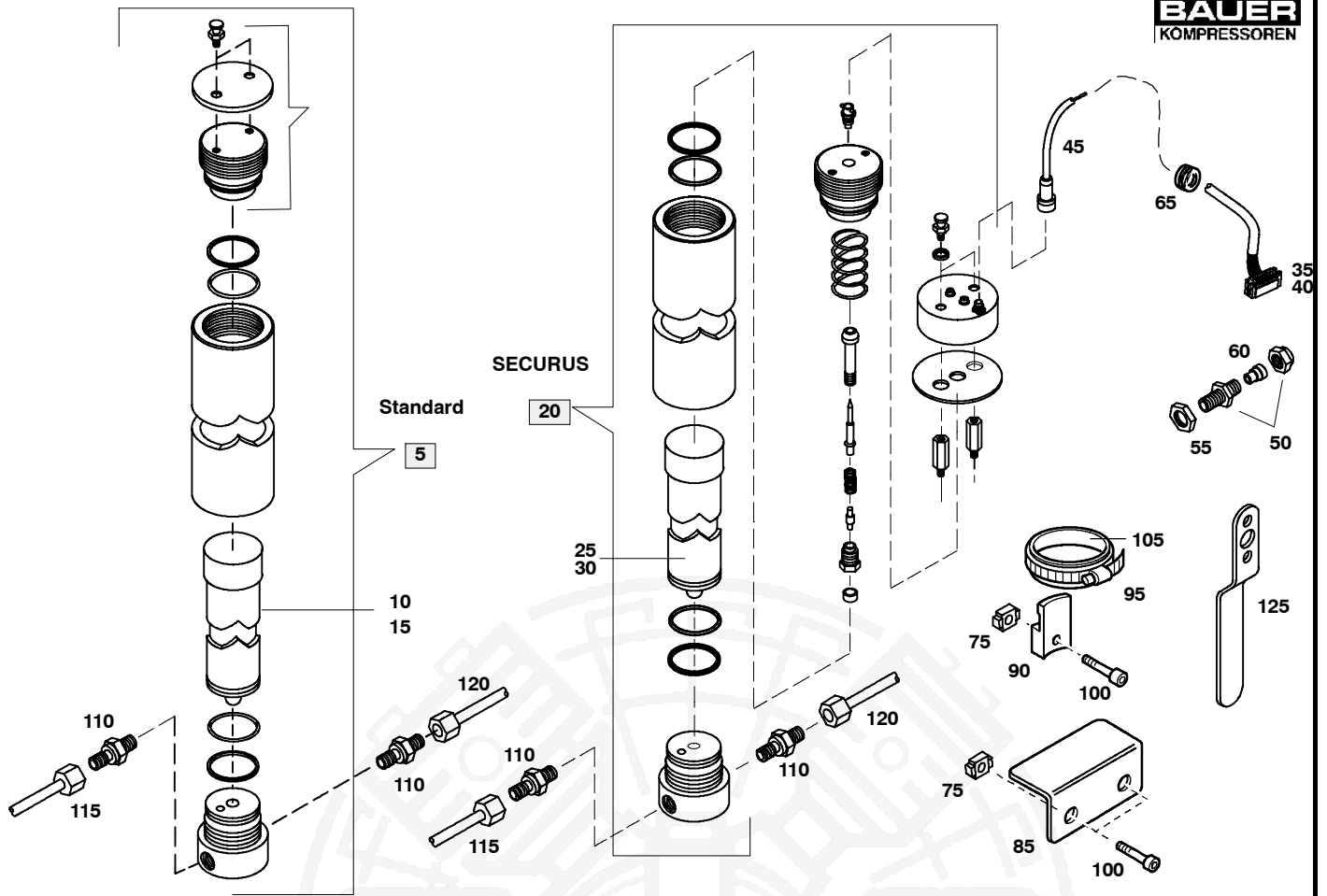



Wartungssätze
Maintenance kits
Kits d'entretien

Baugruppe 075968 **Feinnachreiniger**
Assembly 075968 **Purifier**
Assemblage 075968 **Epurateur**

G24.1- 3

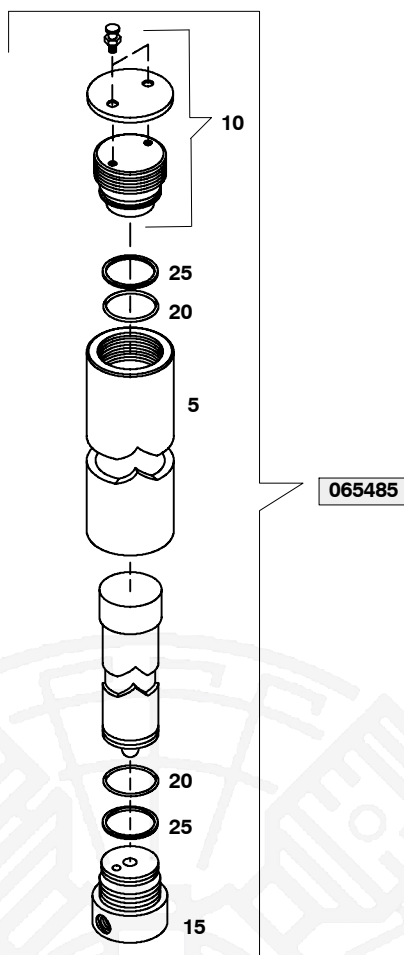
Klasse/ Class/ Classe			Pos.	Bestell-Nr. Part No. No. de cde.	Anz. Qty. Qté.	Benennung	Designation	Dénomination
a	b	c						
			5	065485	1	Filterbehälter	filter	filtre
			10	058825	1	Filterpatrone o. Securus	cartridge w/o Securus	cartouche sans Securus
			15	058826	1	Filterpatrone o. Securus	cartridge w/o Securus	cartouche sans Securus
			20	091040	1	Filterbehälter PN420	filter PN420	filtre PN420
			25	060036	1	Filterpatrone SECURUS	cartridge w. Securus	cartouche avec Securus
			30	060037	1	Filterpatrone SEC+CO	cartridge CO removal	cartouche SEC+CO
			35	N19987	1	Stecker	connector	interrupteur
			40	N19988	1	Abdeckung	plate	couverture
			45	N21762	1	Anschlußleitung kpl.	connecting cable cpl.	conduite de raccordement
			50	N3101	1	Kabelverschraubung	cable union	raccord de câble
			55	N3104	1	Gegenmutter	counternut	contre-écrou
			60	N21728	1	Dichtring	seal	joint
			65	N15626	1	Durchführungsstülle	grommet	passe-fil
			75	N16184	4	Käfigmutter	lock nut	écrou frein
			85	63658	1	Winkel	fastening bow	étrier de fixation
			90	61875	2	Halterung	filter mounting	fixation de filtre
			95	N15499	2	Schlauchschelle	worm gear clamp	collier à filet hélicoïdal
			100	N19533	4	Zylinderschraube	cylinder screw	vis cylindrique
			105	N15500*	mm	Gummiprofil	rubber profile	profilé en caoutchouc
			110	N20404	2	Gerader-Einschraubst.	screwed socket	raccord droit mâle
			111	N3608	2	Überwurfmutter	screw cap	écrou borgne
			112	N3609	2	Schneidring	cutting ring	bague coupante
			115	N3619*	mm	Nahtloses Rohr	stainless steel tube 8x1.5	tuyau en acier inox 8x1.5
			120	N3619*	mm	Nahtloses Rohr	stainless steel tube 8x1.5	tuyau en acier inox 8x1.5
			125	60074	1	Schlüssel	key	clef



Wartungssätze
 Maintenance kits
 Kits d'entretien

Baugruppe 065485
 Assembly 065485
 Assemblage 065485

Filterbehälter
 Filter housing
 Corps de filtre

G24.1- 3a

Klasse/ Class/ Classe			Pos.	Bestell-Nr. Part No. No. de cde.	Anz. Qty. Qté.	Benennung	Designation	Dénomination
a	b	c						
			5	*	1	Behältergehäuse	filter housing	corps de filtre
			10	*	1	Behälterdeckel kpl.	filter head assy.	tête de filtre cpl.
			15	*	1	Behälterboden	filter bottom	fond de filtre
			20	N4736	2	Stützring	back-up ring	bague d'appui
			25	N4735	2	O-Ring	o-ring	joint torique
			30	90761	1	Fabrikschild		
			31	66074	1	Schild		
			32	65963	1	Fabrikschild		
			35	N3334	1	Niete	semitubular rivet	rivet semi-tubulaire
			40	N3333	3	Blindniete	pop rivet	rivet aveugle
			45	91024	1	Klebeschild		

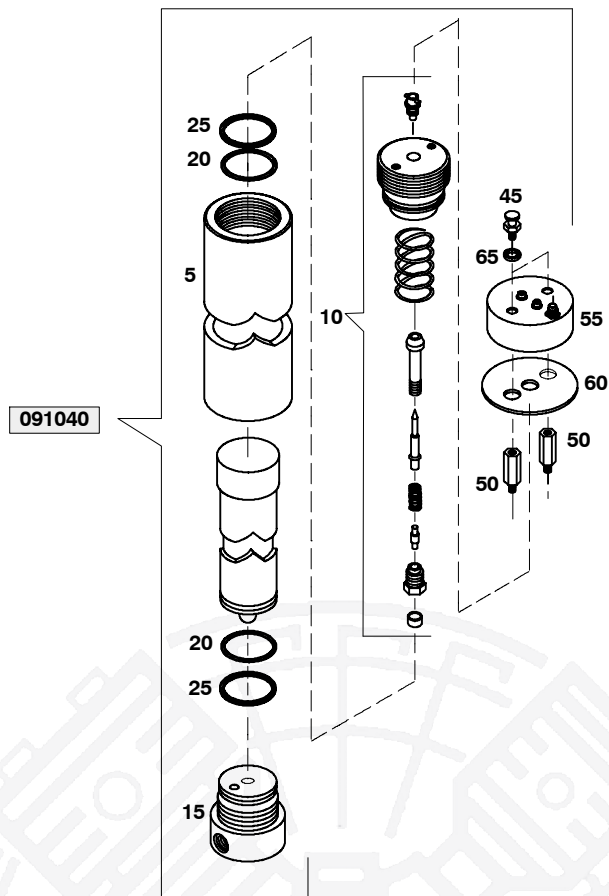

Wartungssätze
 Maintenance kits
 Kits d'entretien

Baugruppe 091040 Filterbehälter
 Assembly 091040 Filter housing
 Assemblage 091040 Corps de filtre

G24.1- 3b

Klasse/ Class/ Classe			Pos.	Bestell-Nr. Part No. No. de cde.	Anz. Qty. Qté.	Benennung	Designation	Dénomination
a	b	c						
			5	*	1	Behältergehäuse	filter housing	corps de filtre
			10	*	1	Behälterdeckel kpl.	filter head assy.	tête de filtre cpl.
			15	*	1	Behälterboden	filter bottom	fond de filtre
			20	N4736	2	Stützring	back-up ring	bague d'appui
			25	N4735	2	O-Ring	o-ring	joint torique
			30	90761	1	Fabrikschild		
			31	66074	1	Schild		
			32	65963	1	Fabrikschild		
			35	N3334	1	Niete	semitubular rivet	rivet semi-tubulaire
			40	N3333	3	Blindniete	pop rivet	rivet aveugle
			45	12293	2	Schraube	fastening screw	vis de fixation
			50	90765	2	Sechskant	distance bolt	boulon d'écartement
			55	090570	1	SECURUS	SECURUS	SECURUS
			60	90715	1	Dichtung	gasket	joint
			65	N20648	2	USIT-Ring	USIT-ring	USIT-anneau
			80	91025	1	Klebeschild		

*

nur kpl. lieferbar

available as cpl. assy- only

ne sont livrées qu'ensemble



